

READ AND SAVE THESE INSTRUCTIONS

INSTALLATION MANUAL

Surface evaporator
Condair **ME Control**

Thank you for choosing Condair

Installation date (MM/DD/YYYY):

Commissioning date (MM/DD/YYYY):

Location ref.:

Model:

Serial number:

Proprietary Notice

This document and the information disclosed herein are proprietary data of Condair Group AG. Neither this document, nor the information contained herein shall be reproduced, used, or disclosed to others without the written authorization of Condair Group AG, except to the extent required for installation or maintenance of recipient's equipment.

Liability Notice

Condair Group AG does not accept any liability due to incorrect installation or operation of the equipment or due to the use of parts/components/equipment that are not authorized by Condair Group AG.

Copyright Notice

© Condair Group AG, All rights reserved.

Technical modifications reserved

Contents

1	Introduction	4
1.1	General	4
1.2	Notes on the installation manual	4
2	For your safety	6
3	Important notes	8
3.1	Inspection of the delivery	8
3.2	Storing/Transportation/Packaging	8
3.3	Product designation / Which model do you have	9
4	Installation	10
4.1	Installation overviews	10
4.1.1	Typical system Condair ME Control, internal install	10
4.1.2	Typical system Condair ME Control, external install with centre drain tank	11
4.1.3	Typical system Condair ME Control, external install with side drain tank (evaporative modules up to 3000 mm wide only)	12
4.2	Schematic flow diagrams Condair ME Control	13
4.3	Mounting the evaporative module	14
4.3.1	Notes on positioning the evaporative module	14
4.3.2	Installation procedure evaporative module	17
4.4	Mounting the hydraulic module	29
4.4.1	Mounting the hydraulic module, internal installation	29
4.4.2	Mounting the hydraulic module, external installation	30
4.5	Mounting the wall feed through plates	33
4.6	Water installation	37
4.6.1	Notes on water installation	37
4.6.2	Water installation (internal installation)	40
4.6.3	Wasser installation (external installation)	41
4.6.3.1	Water installation (external installation, centre drain tank)	41
4.6.3.2	Water installation (external installation, side drain tank)	42
4.7	Mounting the control unit	43
4.7.1	Notes on positioning the control unit	43
4.7.2	Recommended access requirements of the control unit	43
4.7.3	Mounting the control unit	44
4.8	Electrical installation	45
4.8.1	Notes on electrical installation	45
4.8.2	Wiring diagram Condair ME Control	47
4.8.3	Installation work	48
5	Appendix	54
5.1	Inlet water quality requirements	54

1 Introduction

1.1 General

We thank you for having purchased the **Condair ME Control surface evaporator** (Condair ME Control for short).

To ensure a safe, proper, and economical operation of the Condair ME Control, please observe and comply with all information and safety instructions contained in the present documentation as well as in the separate documentations of the components installed in the cooling system. Improper use of the Condair ME Control may result in danger to the user or third parties and/or impairment of material assets.

If you have questions after reading this documentation, please contact your Condair representative. They will be glad to assist you.

1.2 Notes on the installation manual

Limitation

The subject of this installation manual is the Condair ME Control surface evaporator. The various options and accessories are only described insofar as is necessary for proper operation of the equipment. Further information on options and accessories can be obtained in the respective instructions.

This installation manual is restricted to the **installation** of the Condair ME Control and is meant for **well trained personnel being sufficiently qualified for their respective work**.

Please note, some illustrations in this manual may show options and accessories which may not be supplied as standard or available. Please check availability and specification details with your Condair representative.

The installation manual is supplemented by various separate items of documentation (such as the operation manual), which are included in the delivery as well. Where necessary, appropriate cross-references are made to these publications in the installation manual.

Symbols used in this manual



CAUTION!

The catchword "CAUTION" used in conjunction with the caution symbol in the circle designates notes in this installation manual that, if neglected, may cause **damage and/or malfunction of the unit or other material assets**.



WARNING!

The catchword "WARNING" used in conjunction with the general caution symbol designates safety and danger notes in this installation manual that, if neglected, may cause **injury to persons**.



DANGER!

The catchword "DANGER" used in conjunction with the general caution symbol designates safety and danger notes in this installation manual that, if neglected, may lead to **severe injury or even death of persons**.

Safekeeping

Please safeguard this installation manual in a safe place, where it can be immediately accessed. If the equipment changes hands, the documentation must be passed on to the new operator.

If the documentation gets mislaid, please contact your Condair representative.

Language versions

This installation manual is available in various languages. Please contact your Condair representative for information.

2 For your safety

General

Every person working with the Condair ME Control must have read and understood the installation manual and the operation manual of the Condair ME Control before carrying out any work.

Knowing and understanding the contents of the installation manual and the operation manual is a basic requirement for protecting the personnel against any kind of danger, to prevent faulty operation, and to operate the unit safely and correctly.

All ideograms, signs and markings applied to the unit must be observed and kept in readable state.

Qualification of personnel

All work described in this installation manual **may only be carried out by specialists who are well trained and adequately qualified and are authorized by the customer.**

For safety and warranty reasons any action beyond the scope of this manual must only be carried out by personnel with appropriate industry recognised qualifications or training.

It is assumed that all persons working with the Condair ME Control are familiar and comply with the appropriate local regulations on work safety and the prevention of accidents.

Intended use

The Condair ME Control is intended exclusively for **outlet air cooling in AHU's or air ducts** within the specified operating conditions (see operation manual Condair ME Control). Any other type of application, without the written consent of the manufacturer, is considered as not conforming with the intended purpose and may lead to the Condair ME Control becoming dangerous.

Operation of the equipment in the intended manner requires **that all the information contained in this installation manual are observed (in particular the safety instructions).**

Danger that may arise from the Condair ME Control



DANGER!
Risk of electric shock!

The Condair ME control unit (and the optional submerged UV system) contain live mains voltage. Live parts may be exposed when the control unit (or the terminal box of the optional submerged UV system) is open. Touching live parts may cause severe injury or danger to life.

Prevention: The control unit must be connected to the mains only after all mounting and installation work has been completed, all installations have been checked for correct workmanship and the covers has been relocated properly.



WARNING!

Some type of evaporative material is manufactured from glass fibre. Though this material is not classified as hazardous, it is recommended that Personal Protection Equipment such as gloves, protective clothing and eye protection are used during handling to protect the user from fibres or dust. If dust is generated during handling it is recommended that respiratory protection is worn.

Correct lifting and handling

Lifting or handling of components always carries an element of risk, and therefore must only be carried out by trained and qualified personnel. Ensure that any lifting operations have been fully planned and risk assessed. All equipment should be checked by a skilled and competent health & safety representative.

It is the customer's responsibility to ensure that operators are trained in handling heavy goods and to enforce the relevant lifting regulations.

Preventing unsafe operation

All persons working with the Condair ME Control are obliged to report any alterations to the unit that may affect safety to the owner without delay and to **secure such systems against accidental power-up**.

Prohibited modifications to the unit

No modifications must be undertaken on the Condair ME Control without the express written consent of the manufacturer.

For the replacement of defective components use exclusively **original accessories and spare parts** available from your Condair representative.

3 Important notes

3.1 Inspection of the delivery

After receiving:

- Inspect shipping boxes for damage.
Any damages to the shipping boxes must be reported to the shipping company.
- Check packing slip to ensure all parts has been delivered.
All material shortages are to be reported to your Condair representative within 48 hours after receipt of the goods. Condair assumes no responsibility for any material shortages beyond this period.
- Unpack the parts/components and check for any damage.
It is particularly important that the tank, structural components, and fixings (such as studs) are inspected as damage to these items could affect the structural integrity of the system. If parts/components are damaged, notify the shipping company immediately.
- Check whether the components are suitable for installation on your site according to the product specification (refer to model key in the operation manual).

3.2 Storing/Transportation/Packaging

Storing

Until installation store the system components in its original packaging in a protected area meeting the following requirements:

- Room temperature: 1 ... 40 °C
- Room humidity: 10 ... 75 %rh

Transportation

For optimum protection of the product, always transport the unit in its original packaging. The packaged Condair ME unit is able to be transported by trained personnel, using an appropriate lifting/transporting device from the underside.



The evaporative module **must not** be transported with the optional droplet separators fitted.



It is the customer's responsibility to ensure that operators are trained in handling heavy goods and that the operators comply with the appropriate regulations on work safety and the prevention of accidents.

Packaging

Keep the original packaging of the components for later use.

In case you wish to dispose of the packaging, observe the local regulations on waste disposal. Please recycle packaging where possible.

3.3 Product designation / Which model do you have

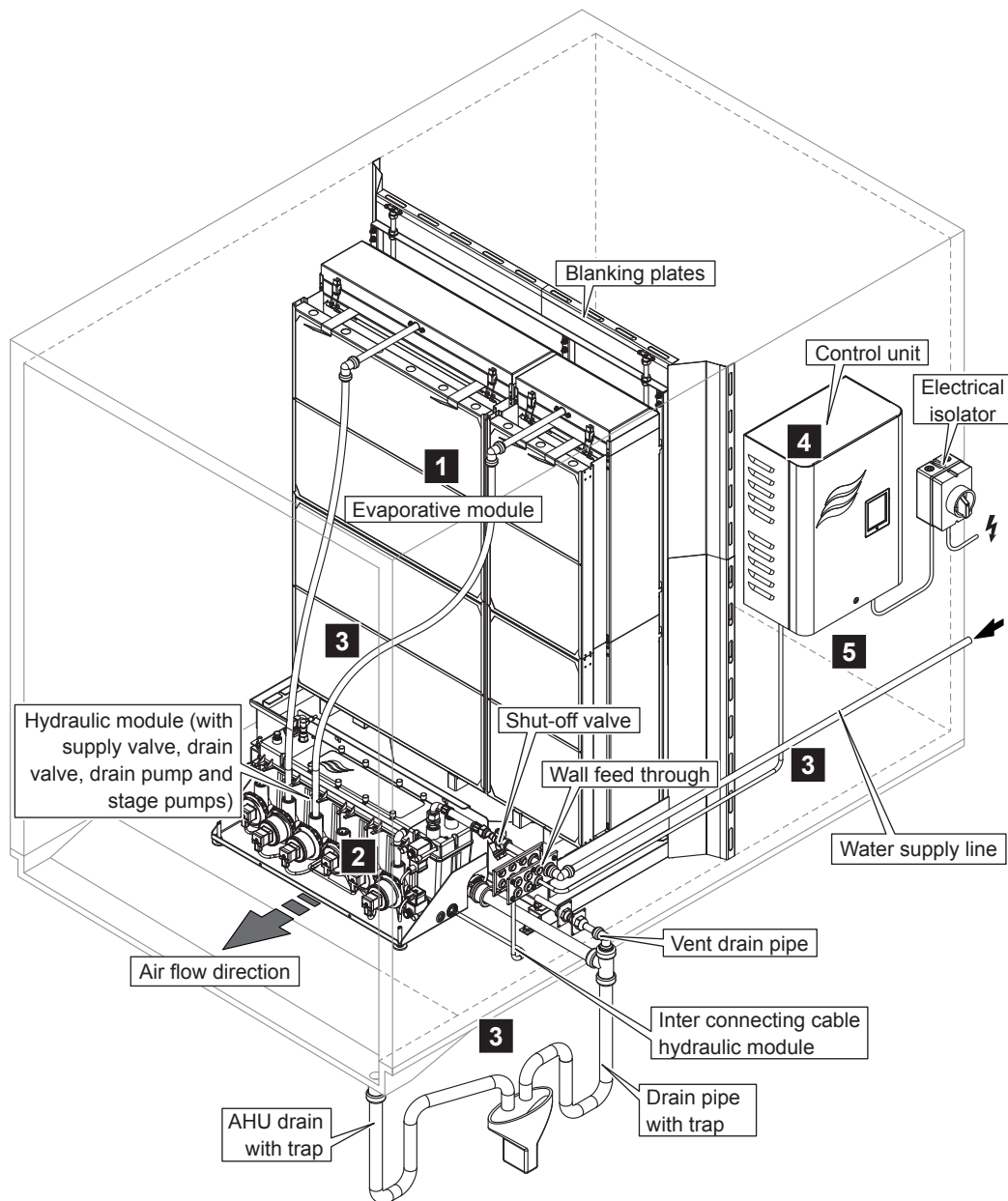
The product designation and the most important unit data are found on the rating plate fixed to the evaporative module and the control unit.

Information regarding the rating plate and the product key can be found in the operation manual of the Condair ME Control.

4 Installation

4.1 Installation overviews

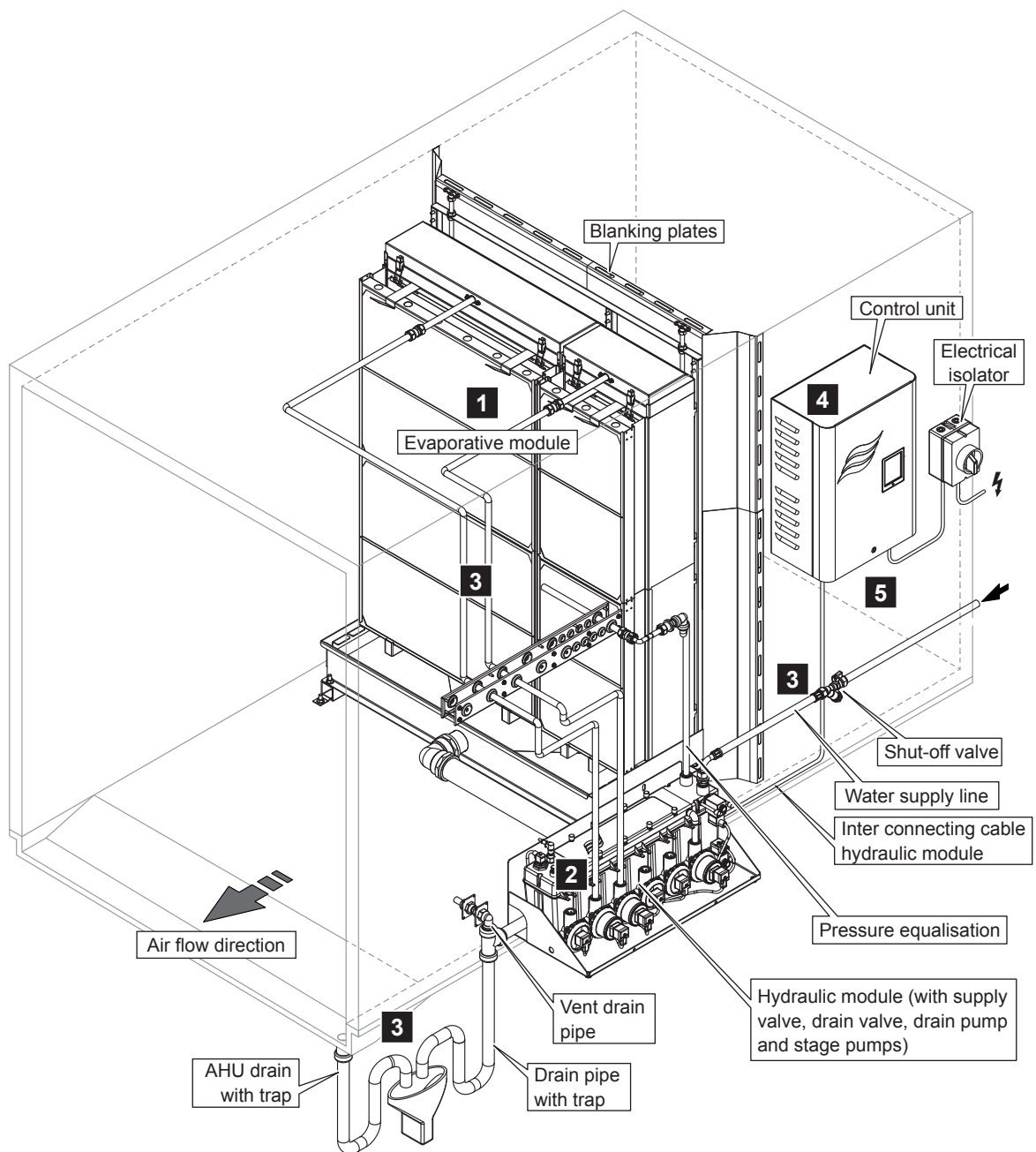
4.1.1 Typical system Condair ME Control, internal install



- 1 - Mounting the evaporative module --> see [chapter 4.3](#)
- 2 - Mounting the hydraulic module --> see [chapter 4.4](#)
- 3 - Water installation --> see [chapter 4.6](#)
- 4 - Mounting the control unit --> see [chapter 4.7](#)
- 5 - Electrical installation --> see [chapter 4.8](#)

Fig. 1: Typical system Condair ME Control, internal install

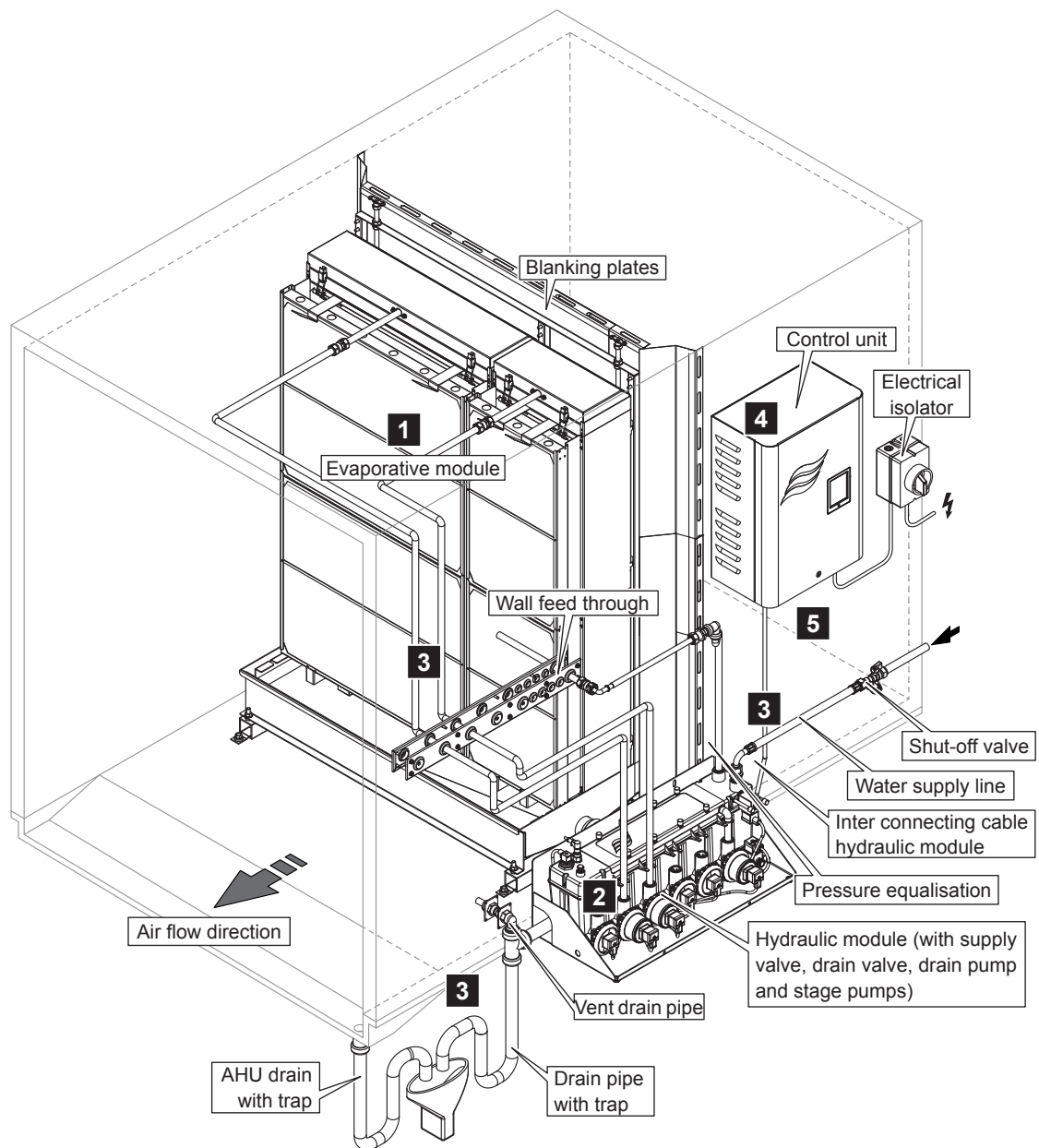
4.1.2 Typical system Condair ME Control, external install with centre drain tank



- 1 - Mounting the evaporative module --> see [chapter 4.3](#)
- 2 - Mounting the hydraulic module --> see [chapter 4.4](#)
- 3 - Water installation --> see [chapter 4.6](#)
- 4 - Mounting the control unit --> see [chapter 4.7](#)
- 5 - Electrical installation --> see [chapter 4.8](#)

Fig. 2: Typical system Condair ME Control, external install with centre drain tank

4.1.3 Typical system Condair ME Control, external install with side drain tank (evaporative modules up to 3000 mm wide only)



- 1 - Mounting the evaporative module --> see [chapter 4.3](#)
- 2 - Mounting the hydraulic module --> see [chapter 4.4](#)
- 3 - Water installation --> see [chapter 4.6](#)
- 4 - Mounting the control unit --> see [chapter 4.7](#)
- 5 - Electrical installation --> see [chapter 4.8](#)

Fig. 3: Typical system Condair ME Control, external install with side drain tank (evaporative modules up to 3000 mm wide only)

4.2 Schematic flow diagrams Condair ME Control

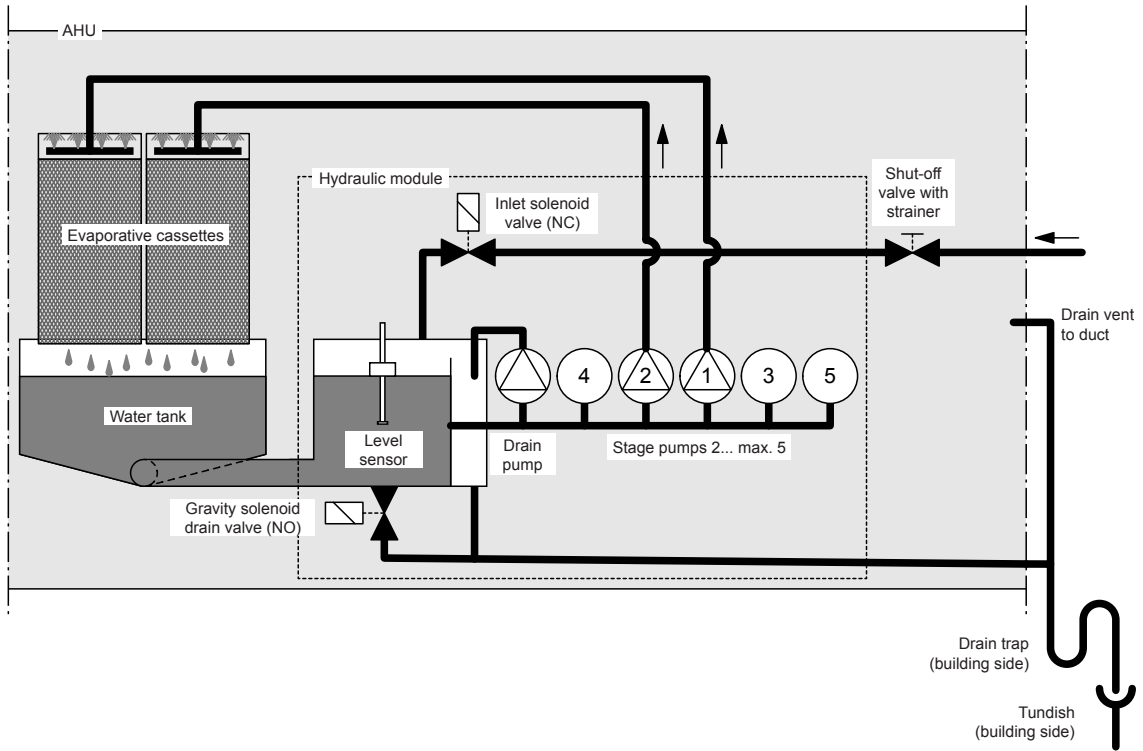


Fig. 4: Schematic flow diagram Condair ME Control (internally mounted)

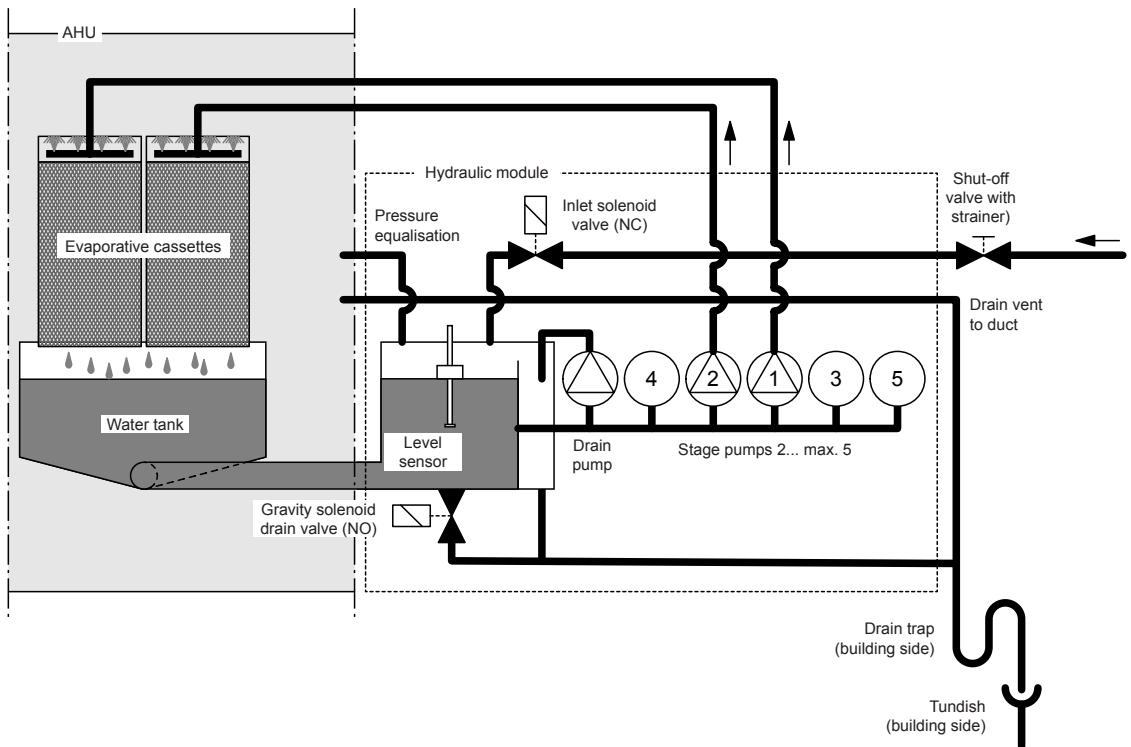


Fig. 5: Schematic flow diagram Condair ME Control (externally mounted)

4.3 Mounting the evaporative module

4.3.1 Notes on positioning the evaporative module

The design and dimensioning of the AHU/air duct as well as the location of the evaporative module inside the duct are determined, recorded and set compulsory when planning the entire system. Prior to installation, however, make sure the following criteria have been taken into consideration:

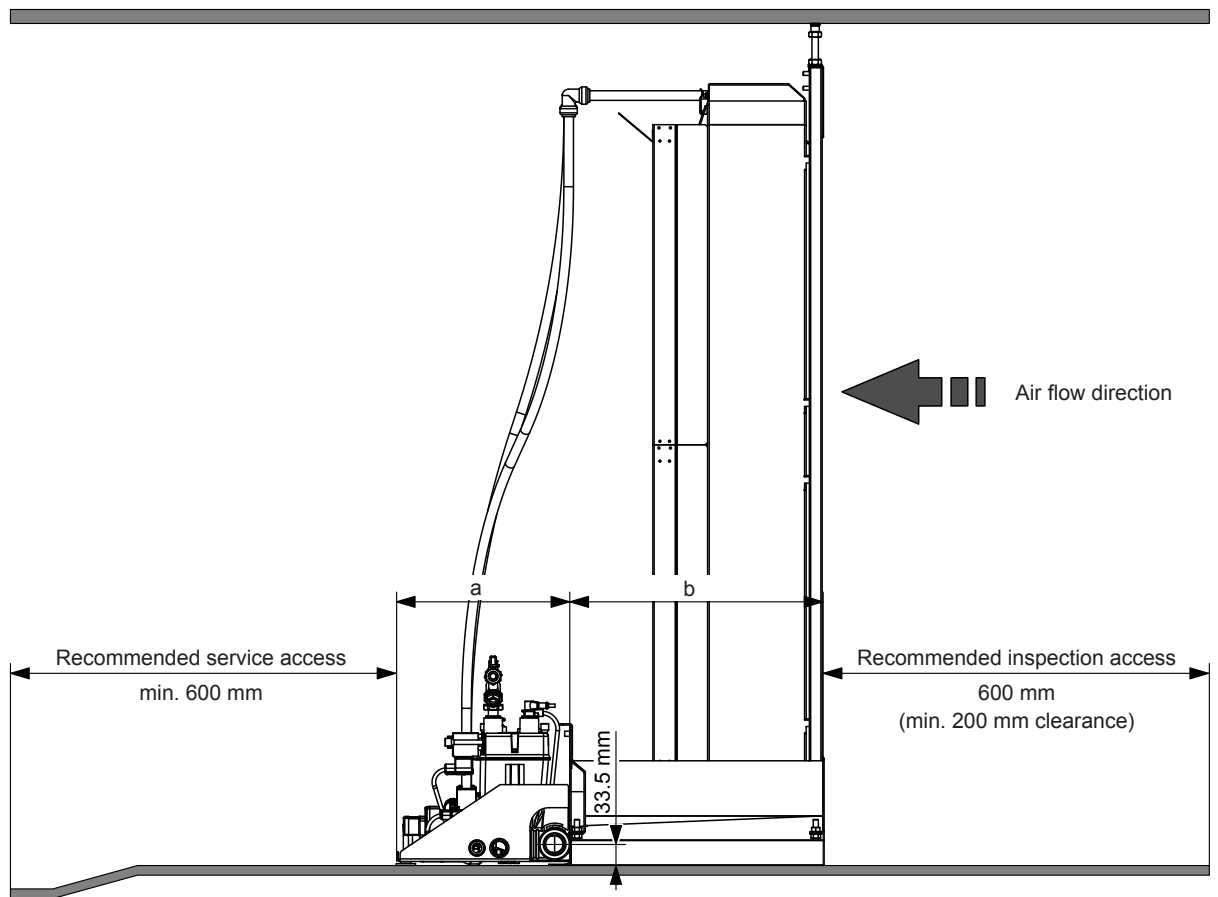
- The AHU/air duct floor must be designed with a loading capacity capable of supporting the evaporative module's weight.
- In the area where the evaporative module is installed the floor of the AHU/air duct must offer a plane support (lengthwise and crosswise).
- The evaporative module must be installed in a **waterproof** section of the AHU/air duct.
- Downstream, directly after the evaporative module a **drain pan with provision for running water to waste** must be installed. The drain must be connected via a drain trap to the waste water line of the building. The drain trap must be sufficiently high and must be filled with water prior to commissioning, so that the drain trap is not emptied by the air pressure in the duct. The drain pan and the drain trap must be accessible for cleaning and disinfection as part of the periodic maintenance of the system.
- For installation and maintenance sufficiently large access doors before and after the evaporative module must be available in the AHU/air duct.
- The supply air must be filtered. We recommend to install an **air filter with quality standard F7 (EU7)** or better before the evaporative module. If no air filter or an air filter with lower quality is installed an increased maintenance will result.
- An **even air flow over the full cross section** of the evaporative module must be guaranteed. If necessary, rectifiers or perforated plates must be installed.
- The evaporative module must be positioned on upstands (supplied) to allow to install the drain pipe with a downslope through the side wall of the AHU/air duct.
- In case of low ambient temperature the AHU/air duct must be insulated to prevent the moist air from condensing inside the duct.
- If the AHU is equipped with a heater, make sure it is at least 600 mm away from the evaporative module.
- If the evaporative module includes the optional droplet separator cassettes for high air velocities, then the droplet separator cassettes must be installed.
- Appropriate clearance must be available for the hydraulic module (and associated plumbing) when installing externally.
- For commissioning and maintenance we recommend a **minimum** of 600 mm of free space after the evaporative module.



WARNING!

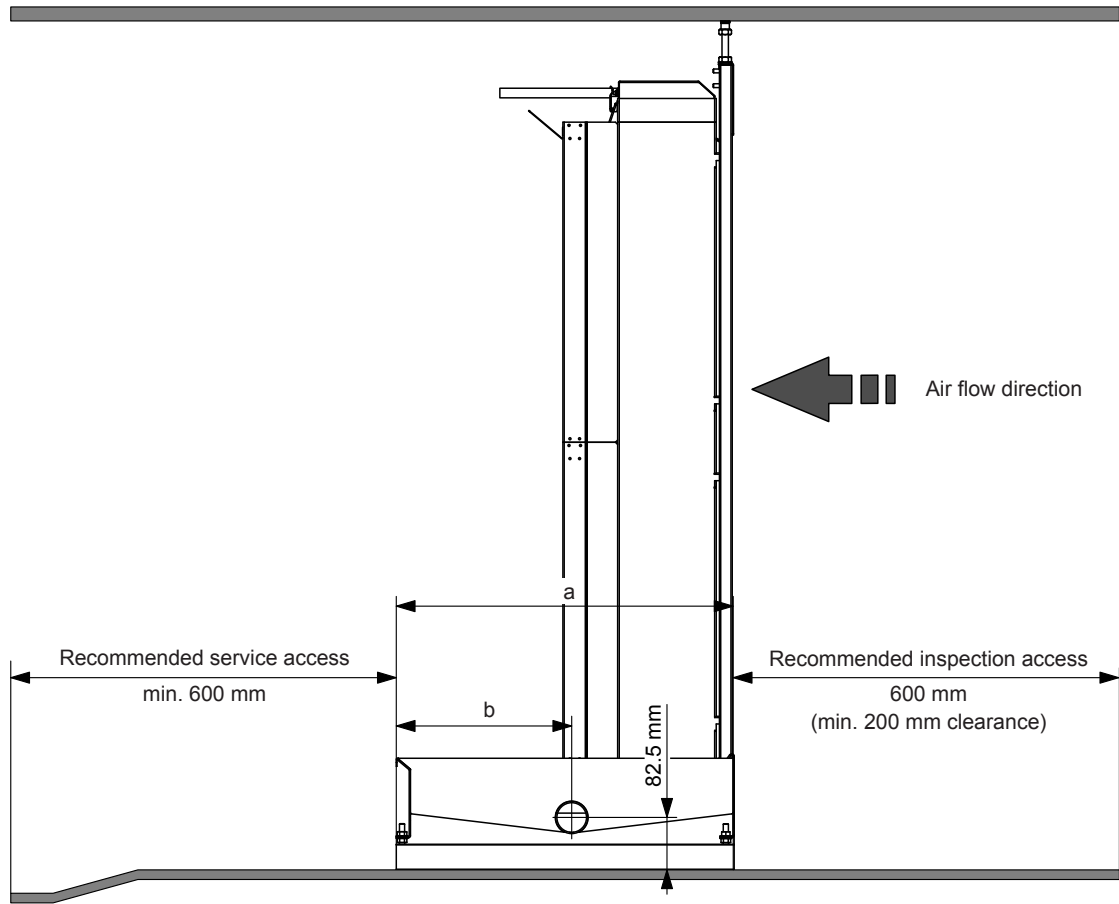
Consideration should be given to the amount of space required after the evaporative module for access equipment, particularly for taller systems as personnel will require access to the top of the evaporative module.

- For inspection we recommend 600 mm of free space before the evaporative module. If inspection access is not required before the module, a minimum clearance of 200 mm is acceptable provided any heater is at least 600 mm away from the evaporative module.



Dimension "a":	
ME Control (internal mounting):	272 mm
ME Control (external mounting):	111 mm
Dimension "b":	
C-Type fibre cassettes C85/C95:	525 mm
Polyester cassettes P85/P95:	525 mm

Fig. 6: Positioning of the evaporative module (centre drain tank)



Dimension "a":	
C-type fibre cassettes C85/C95:	525 mm
Polyester cassettes P85/P95:	525 mm
Dimension "b":	
C-type fibre cassettes C85/C95:	273 mm
Polyester cassettes P85/P95:	273 mm

*Fig. 7: Positioning of the evaporative module
(side drain tank, for evaporative modules ≤ 3000 mm wide only)*

! CAUTION!

The ME evaporative module contains a large reservoir of water when in operation. Install the ME unit where is no risk of water damage, otherwise make provisions to contain any leakage.

4.3.2 Installation procedure evaporative module



WARNING!

All installation work described in this installation manual **may only be carried out by specialists who are well trained and adequately qualified and are authorized by the customer.**

For safety and warranty reasons any action beyond the scope of this manual must only be carried out by personnel with appropriate industry recognised qualifications or training.

It is assumed that all persons working with the Condair ME Control are familiar and comply with the appropriate local regulations on work safety and the prevention of accidents.

1. Mounting the tank upstands to the tank:

- Mounting the **tank upstands supplied by Condair**: fix tank upstands at the appropriate positions to the tank as shown in the figure below using the nuts (M8, AF: 13 mm) and washers supplied.

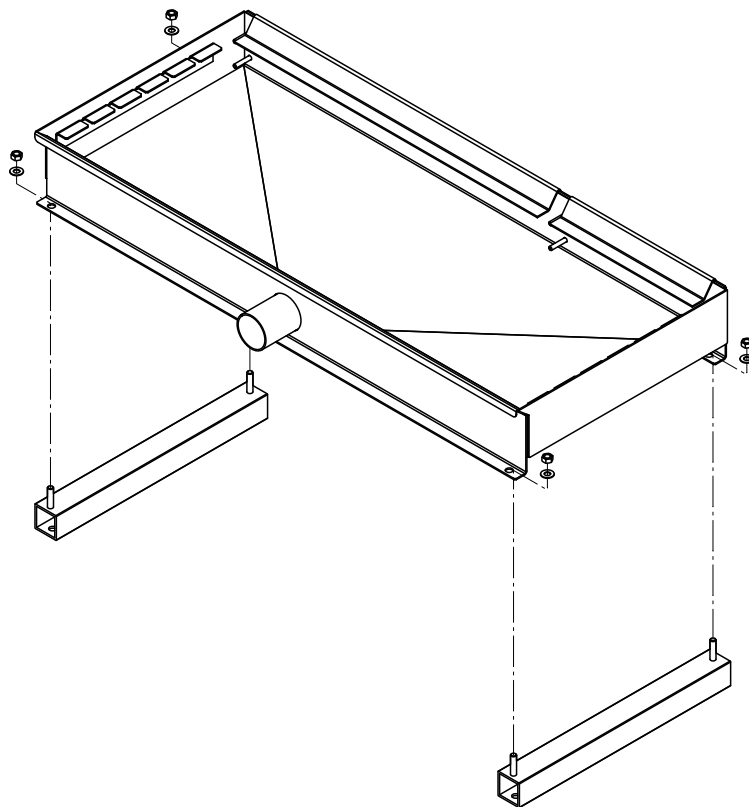


Fig. 8: Mounting the tank upstands to the tank

2. Mounting the tank:

- Insert the tank into the AHU/air duct.



WARNING!

Use an appropriate lifting device or handle the tank with the help of another person to position it inside the duct. It is the customer's responsibility to ensure that operators are trained in handling heavy goods and to enforce the relevant lifting regulations.

- Align the tank to the centre of the duct and perpendicular to the duct walls. When aligned fix tank upstands to the duct floor.



CAUTION!

The installer must take appropriate measures to ensure that the duct floor remains water proof once the tank upstands has been fixed to the duct floor.

- Check that the tank is lengthwise and crosswise exactly horizontal using a level.

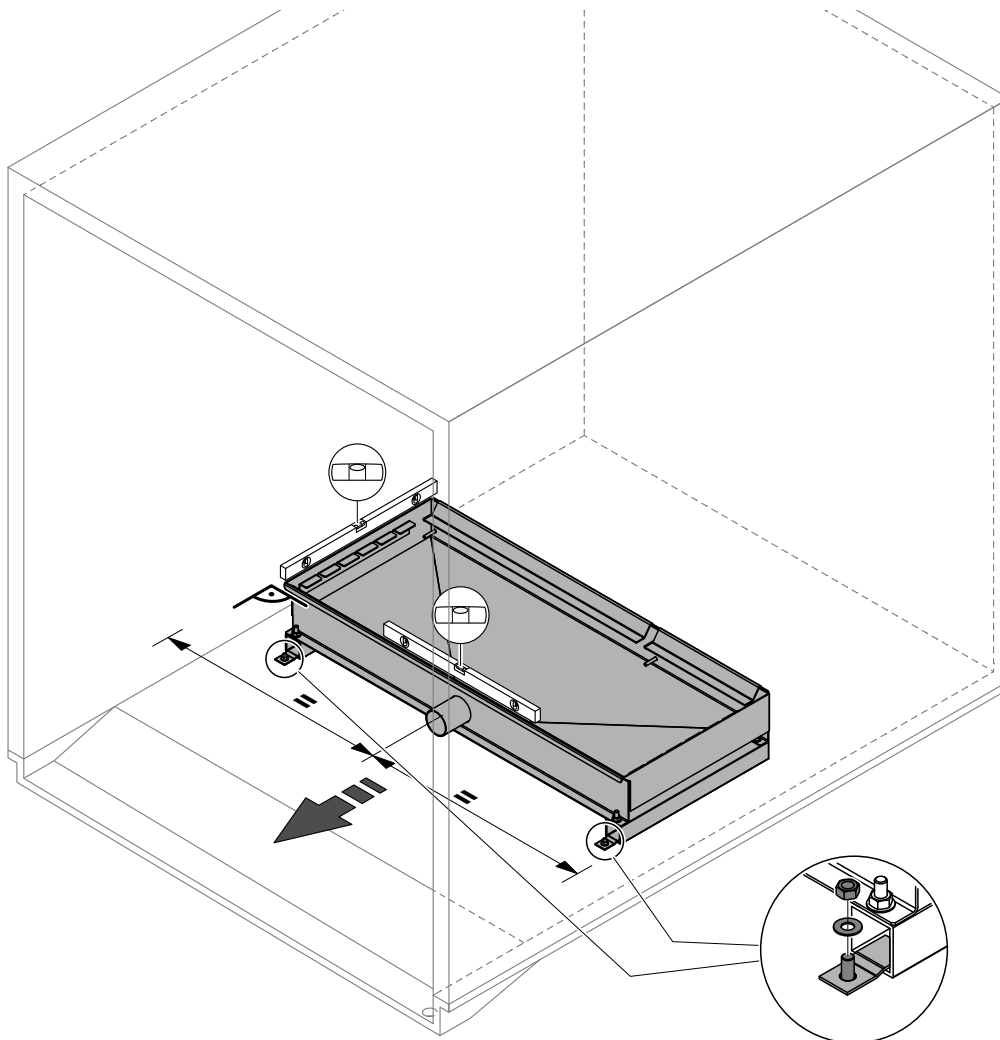


Fig. 9: Mounting the tank

3. Fix frame to the tank:

- Fix the vertical supports to the tank using the nyloc nuts (M6, AF: 10 mm) and M6 washers. Then, align the vertical supports exactly vertical using a level and tighten the nuts.
- Fix the cross member to the vertical supports using the nyloc nuts (M6, AF: 10 mm) and M6 washers. Then, tighten the nuts.

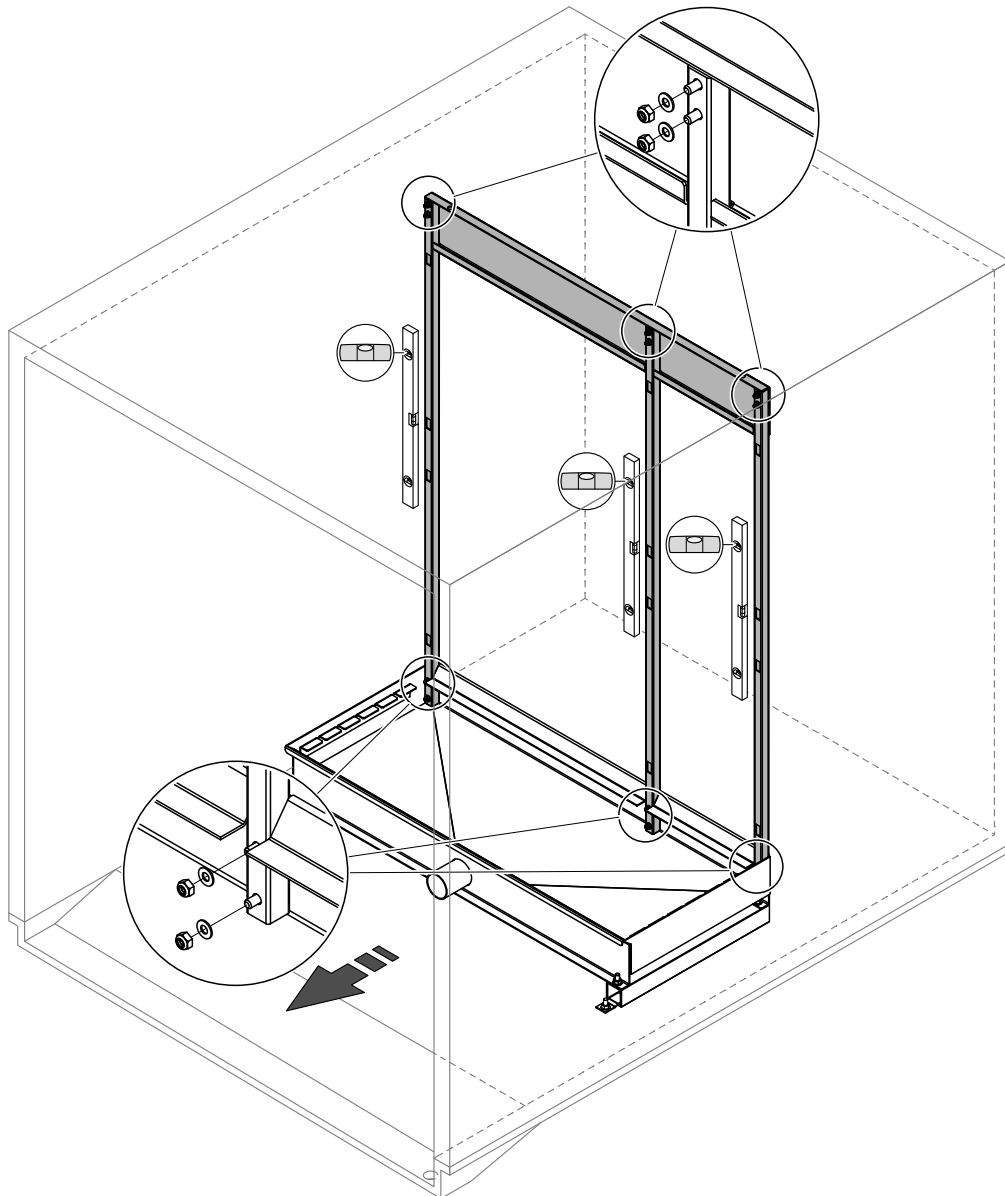


Fig. 10: Fixing frame to tank

4. Fix cross member of frame to AHU/duct ceiling:

- Fix the cross member to the AHU/duct ceiling using appropriate fixings (supplied as part of the installation kit). Before tightening the screws (not supplied) align the vertical supports exactly vertical using a level.



WARNING!

If the cross member is not secured to the AHU/duct ceiling there is a risk that the evaporative module could fall over, potentially causing injury or damage.

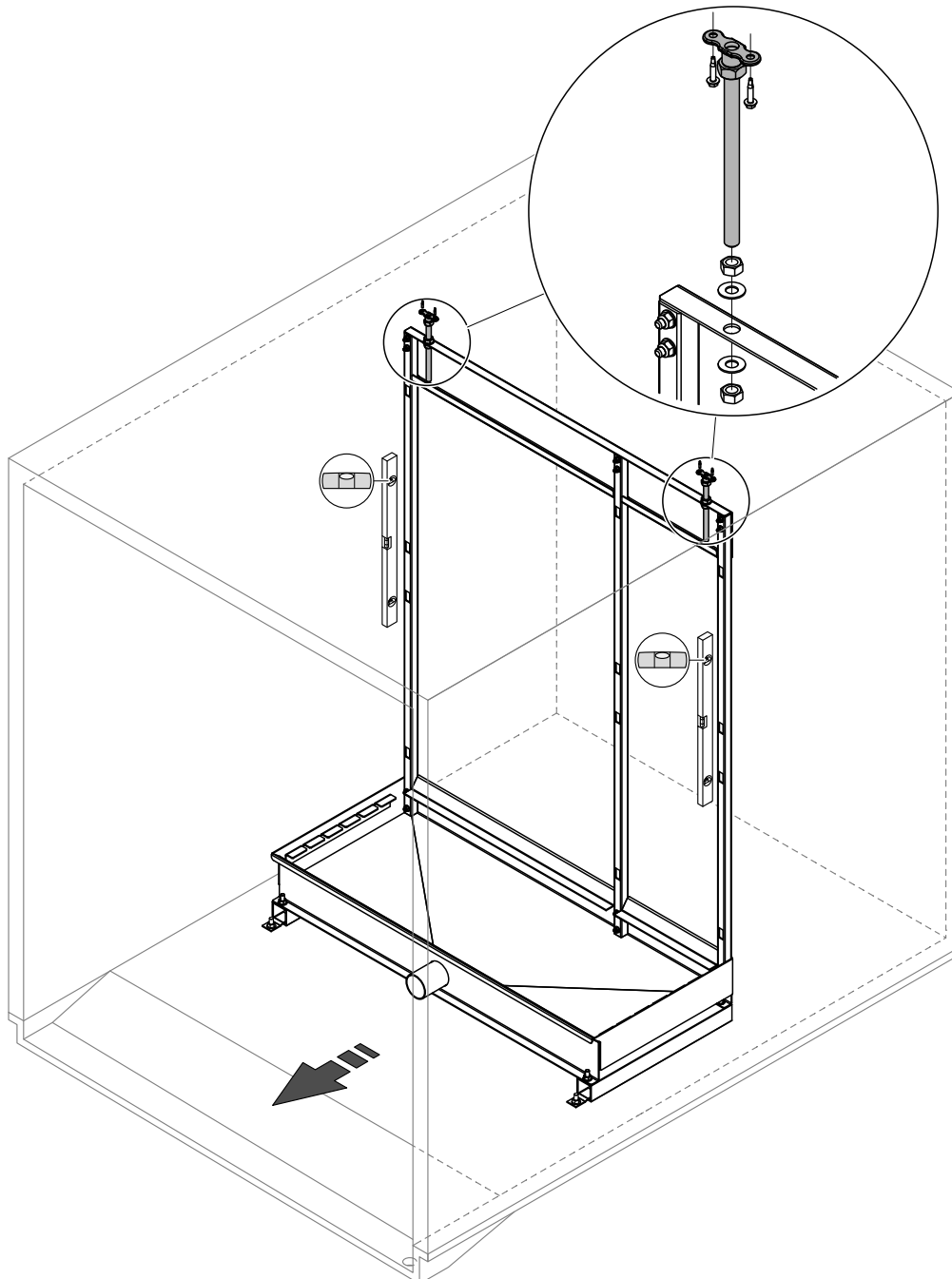


Fig. 11: Fix cross member to AHU/duct ceiling

5. Mount the blanking plates on the air inlet side (blanking plates available as option):

- Starting on each duct side at the bottom fix the side blanking plates to the duct wall using appropriate fixings. Before fixing make sure the side blanking plates are aligned exactly vertical and the free end of the blanking plates touches the side of the corresponding vertical support.
- Starting on one side fix the upper blanking plates to the duct ceiling using appropriate fixings. Before fixing make sure the upper blanking plates are aligned exactly perpendicular to the duct walls and the free ends of the blanking plates touch the cross member of the frame. Also ensure the ends of the blanking plates are touching the side blanking plates.
- Starting on one side fix the lower blanking plates to the duct floor using appropriate fixings. Before fixing make sure the lower blanking plates are aligned exactly perpendicular to the duct walls and the free ends of the blanking plates touch the tank wall. Also ensure the ends of the lower blanking plates are touching the side blanking plates.



CAUTION!

The installer must take appropriate measures to ensure that the duct floor remains water proof once the lower blanking plates have been fixed to the duct floor.

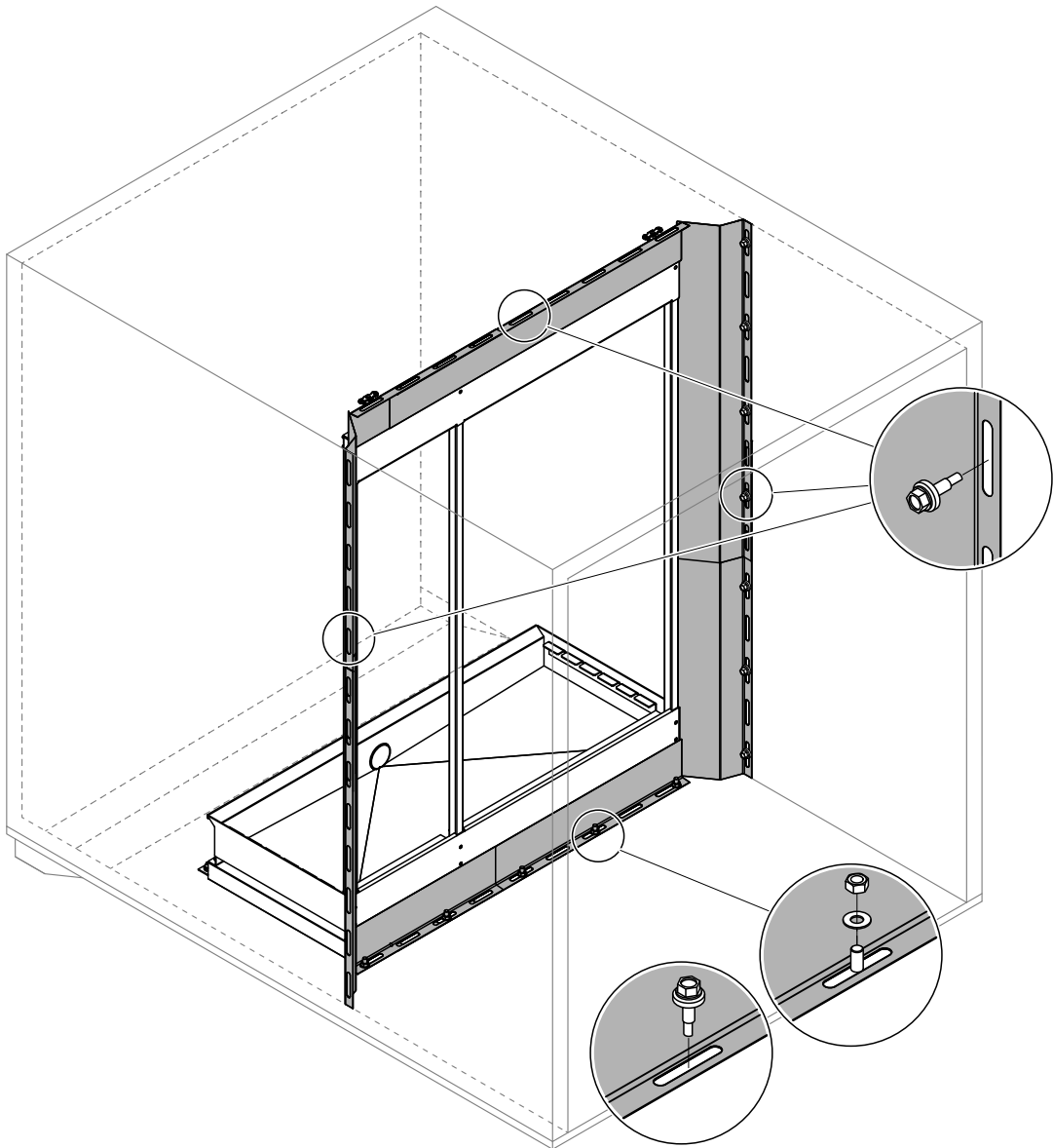


Fig. 12: Mounting the optional Condair blanking plates on the air inlet side

6. Mounting the crossbar:

- **This step must be carried out only on larger systems to prevent bending of the crossbar:**
Fix the supplied crossbar support(s) to the tank using the M6 cross-head bolt and the to stop nuts (M8, AF: 13 mm) according to the figure below.

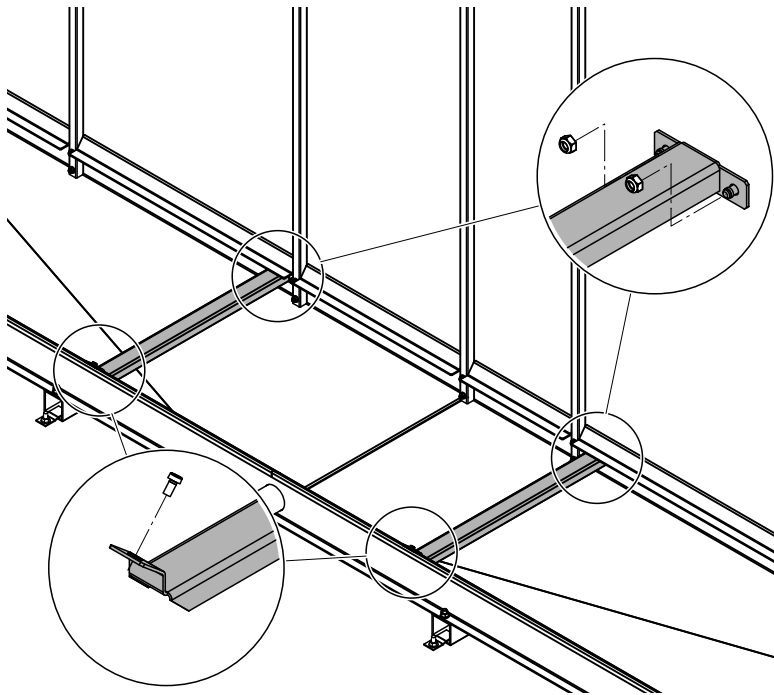


Fig. 13: Mounting the crossbar support(s)

- Put the cross bar on the corresponding cross bar bracket with a distance of "A" to the vertical support (see table below). The cross bar should be positioned so that the evaporative cassettes sit on the edge of the cross bar, and the slots in the side of the cross bar should face the air-off side of the evaporative module as shown below.

Type evaporative cassette (according to rating plate)	Dimension A (nominal)
P85	200 mm (8")
P95	300 mm (12")
C85	200 mm (8")
C95	300 mm (12")

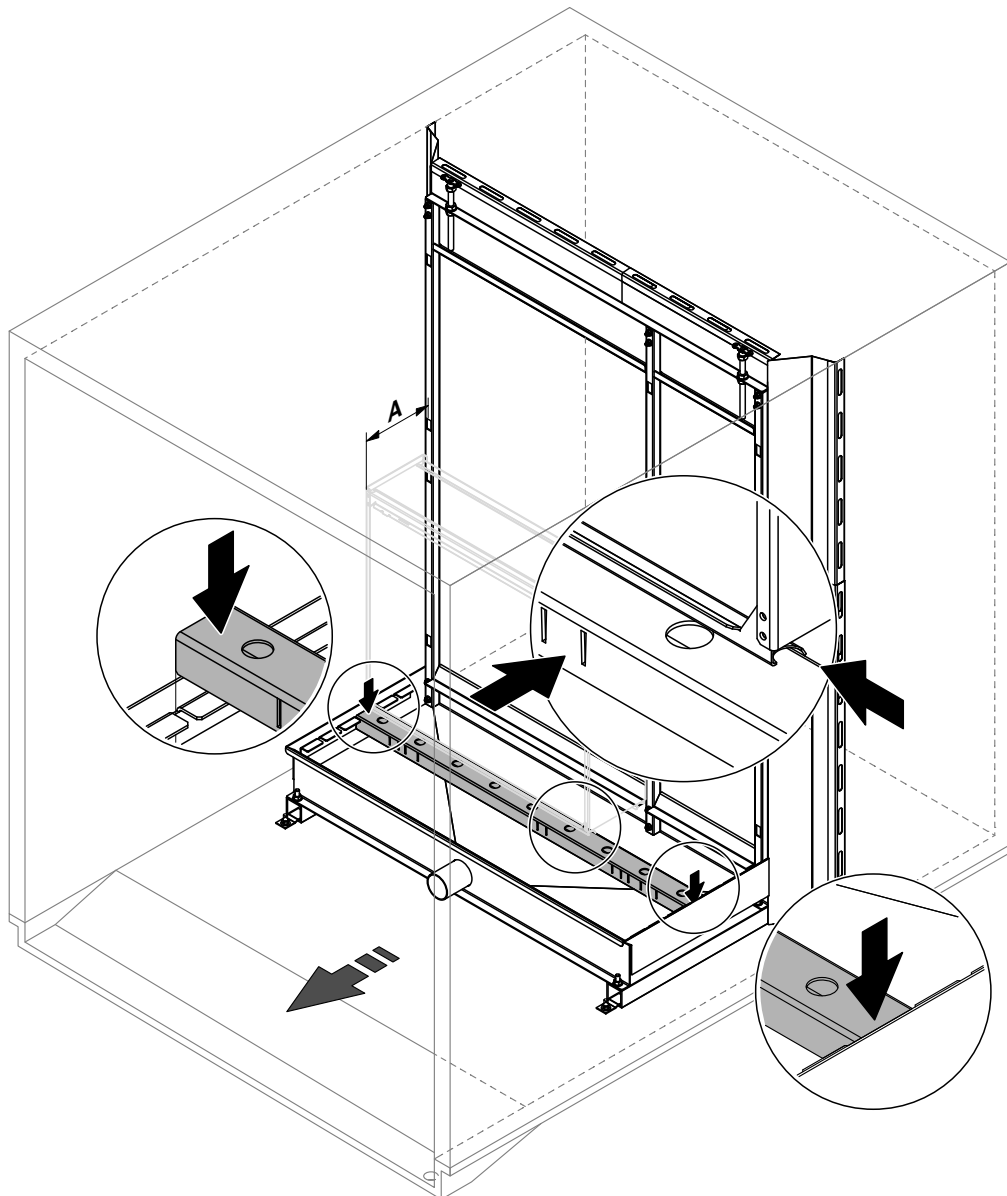


Fig. 14: Mounting the cross bar

7. Mount optional submerged UV, if applicable:

If your system is equipped with the submerged UV mount UV bulb assembly to the cross bar and the junction box to the tank in accordance with the separate manual for this option.

8. Mount distribution head assembly to the topmost evaporative cassettes:

Note: The topmost evaporative cassettes will be the ones that are shortest (vertically).

- **This step must only be carried out on evaporative cassettes with glass fibre media:** mount the appropriate distribution cassettes onto the corresponding evaporative cassettes, by hooking the return on the underside of the distribution cassette under the top strut of the evaporative cassette.
- Mount the appropriate distribution heads onto the corresponding evaporative cassettes or distribution cassettes respectively, by hooking the return on the underside of the distribution head under the top strut of the cassette below. Then secure the distribution heads to the evaporative cassettes using the locking clamps on the distribution heads.

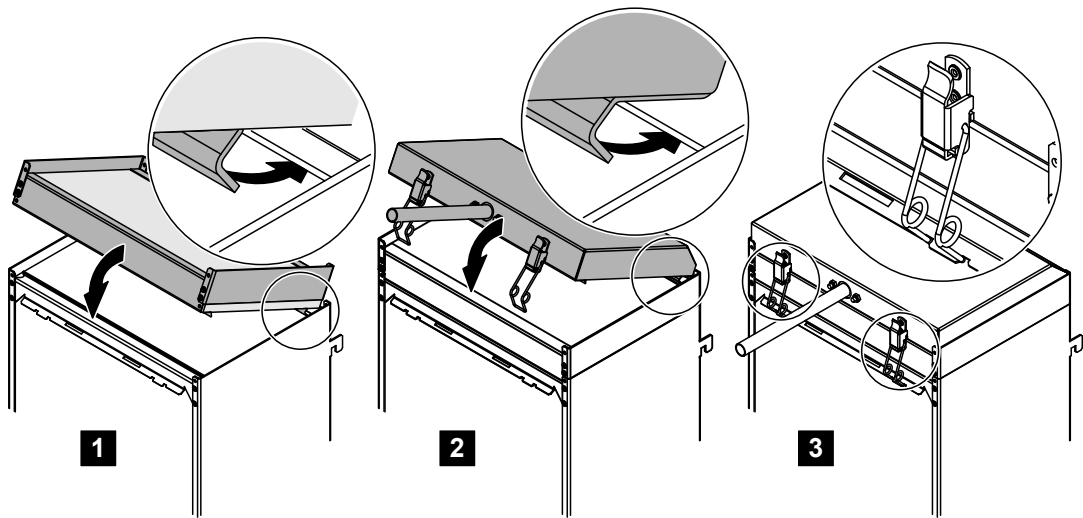


Fig. 15: Mounting the distribution head assembly onto glass fibre evaporative cassettes

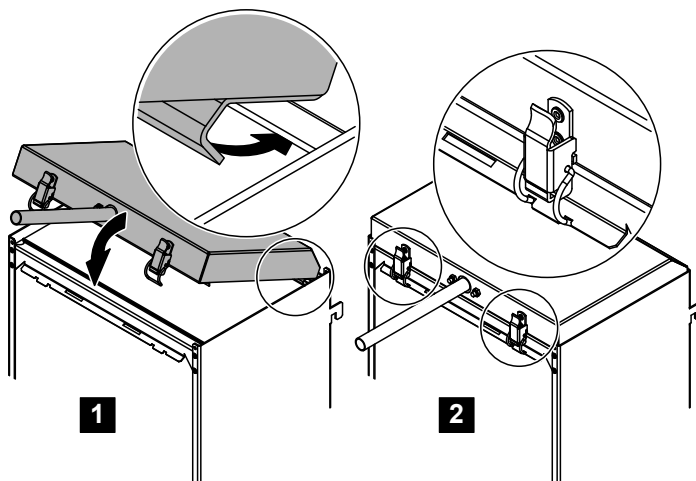


Fig. 16: Mounting the distribution head assembly onto polyester evaporative cassettes

9. Mount evaporative cassettes:

Which type of evaporative cassettes for which type of water!

Type evaporative cassette	Suitable for
Polyester	Tap water, fully softened or partly softened water and fully demineralised water
Fibre	Tap water and fully softened or partly softened water

Note: to avoid damage to the evaporative cassettes during transit, we recommend that the evaporative cassettes are fitted on site.

- Before installing the evaporative cassettes sweep the interior of the tank.
- Starting with the tallest evaporative cassettes on the bottom and working up to the shortest evaporative cassette on the top, hook the cassettes into the vertical supports. Make sure the overlying cassettes slip properly into each other.

Note: The narrowest evaporative cassettes should be positioned near the center of the tank, and the widest evaporative cassettes should be positioned at the right and left ends of the tank (see [Fig. 18](#)).

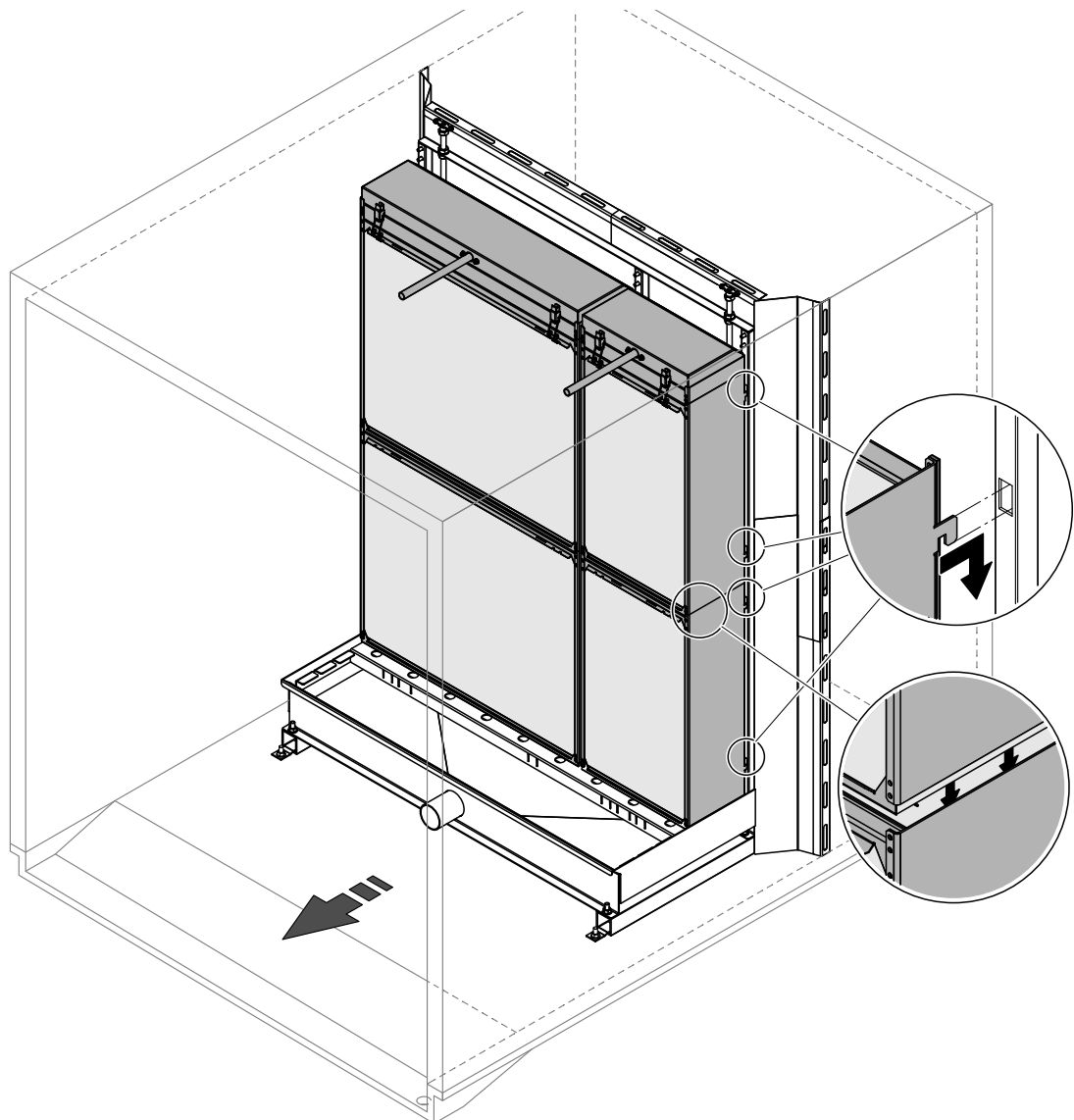


Fig. 17: Mounting the evaporative cassettes

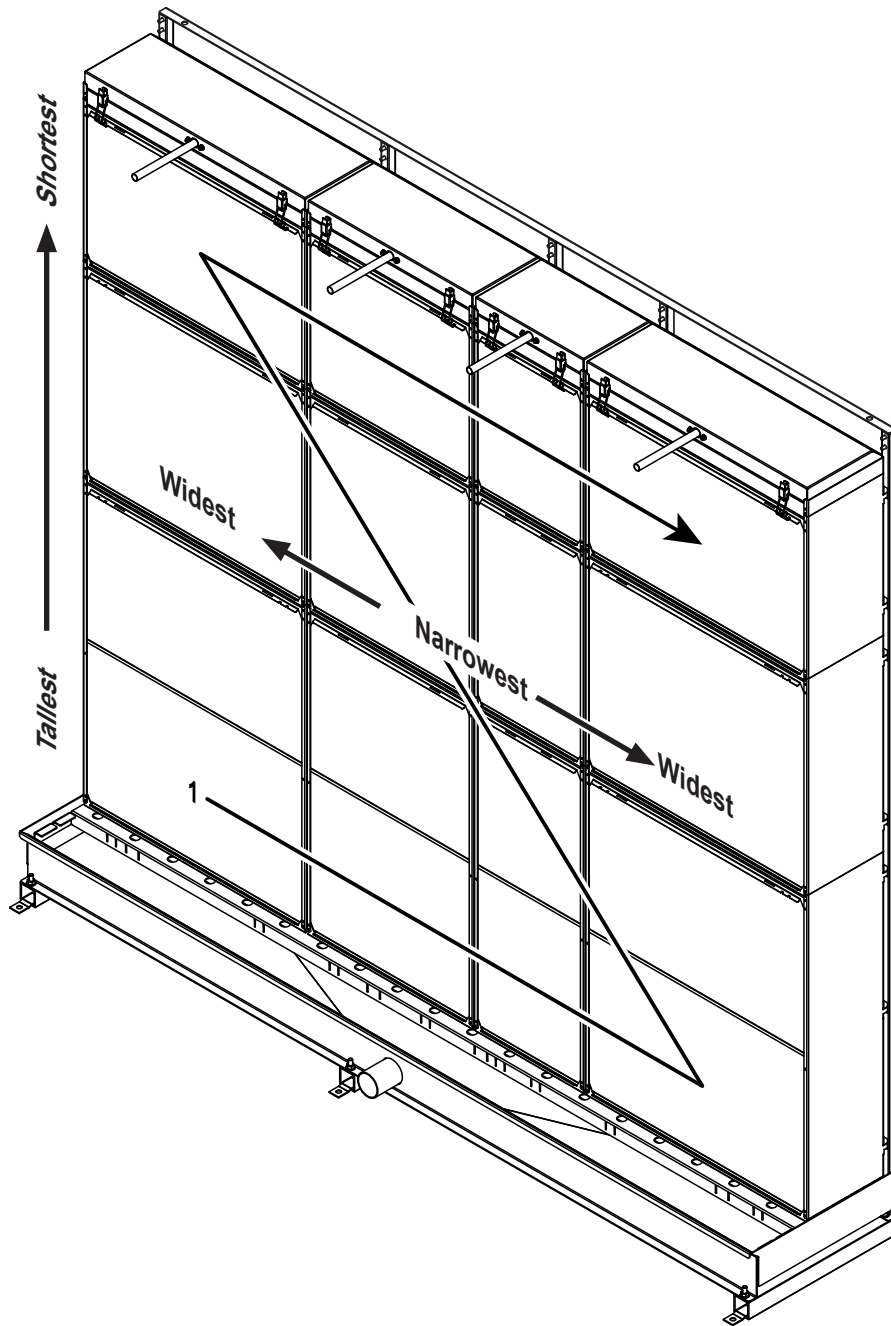


Fig. 18: Mounting order and positioning of the evaporative cassettes

10. Mount the droplet separator cassettes (this step must only be carried out, if your system is equipped with a droplet separator):

Note: To avoid damage to the droplet separator cassettes during transit, the droplet separator cassettes must be fitted on site.

10a. Fit the droplet separator brackets to the top of each bank of evaporative cassettes:

- Release the locking clamps holding each distribution head assembly in place.
- Lift the distribution head and distribution cassette slightly and insert the hem-folded end of the two separator brackets into the recess in the top strut of the uppermost evaporative cassette, position each bracket above the slots in the cassette strut.
- Reseat the distribution cassette and distribution head to grip the separator brackets in place and secure them using the distribution assembly locking clamps.

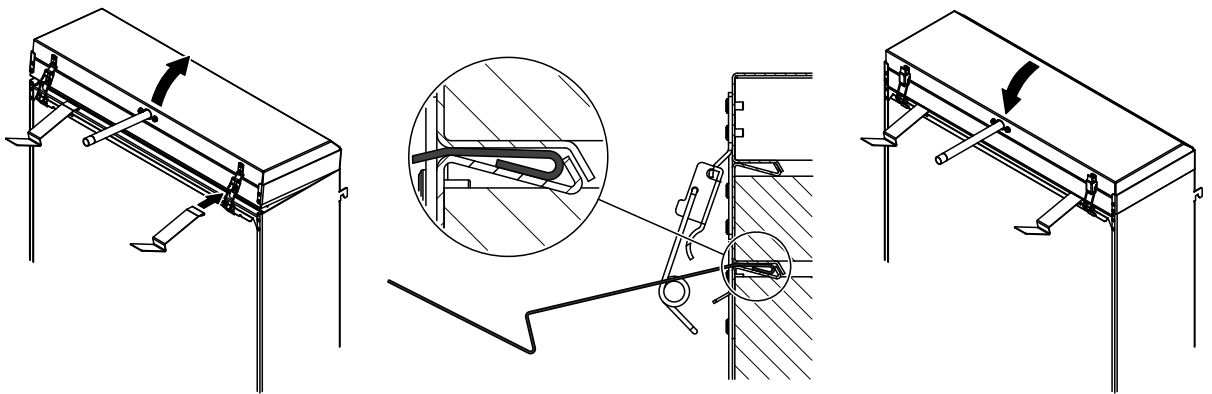


Fig. 19: Mounting the droplet separator brackets

10b. Assemble the separator cassette banks:

- Starting with the tallest droplet separator cassettes on the bottom, and working towards the shortest cassettes at the top, rivet the banks of the droplet separator cassettes together using a rivet gun with \varnothing 3.2 mm (0.13") blind rivets. Make sure the overlying cassettes slip properly into the subjacent cassettes.

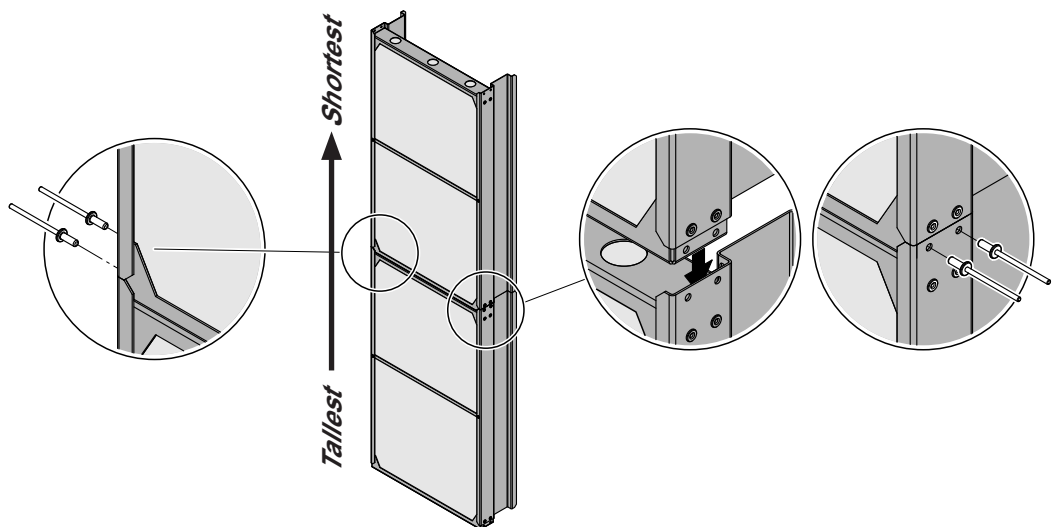


Fig. 20: Riveting the banks of the droplet separator cassettes together

10c. Mount the separator cassette banks:

- Hook the lower separator brackets into the cross bar.
- Then, starting on one side place one separator bank after the other onto the lower separator brackets, align with the evaporative cassette banks and ensure the framework of the droplet separators fit around the metal frames of the evaporative cassettes. Slide the top eliminator cassette under the separator brackets until they spring back down and secure the separator cassette bank firmly in place.

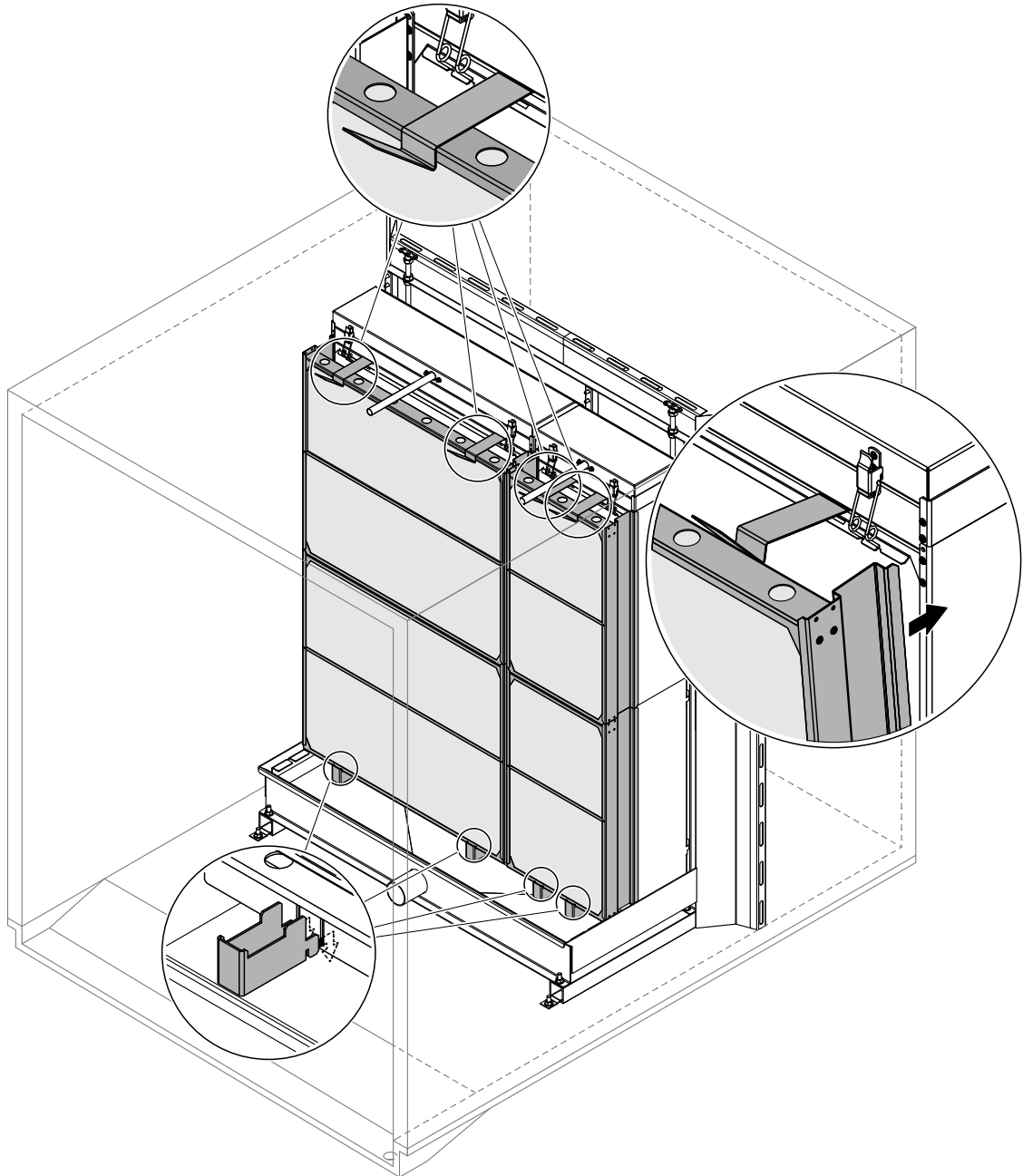


Fig. 21: Mounting the droplet separator banks

4.4 Mounting the hydraulic module

The mounting procedure of the hydraulic module depends on whether or not the hydraulic module is mounted internal or external to the duct.

4.4.1 Mounting the hydraulic module, internal installation

1. Apply **silicone free grease** (e.g. gasket grease) onto the surface of the tank connector and onto the surface of the rubber sealing inside the connector of the hydraulic module.
2. Then, slide the connector bore of the hydraulic module carefully onto the tank connector until it comes to a stop.
3. **With the help of a spirit level and the levelling feet on the bracket, align the hydraulic module exactly horizontal in both planes, i.e. front to back and left to right.** Then, fix the hydraulic module to the tank using the bracket, nuts (M8, AF: 13 mm) and washers supplied and tighten the nuts.

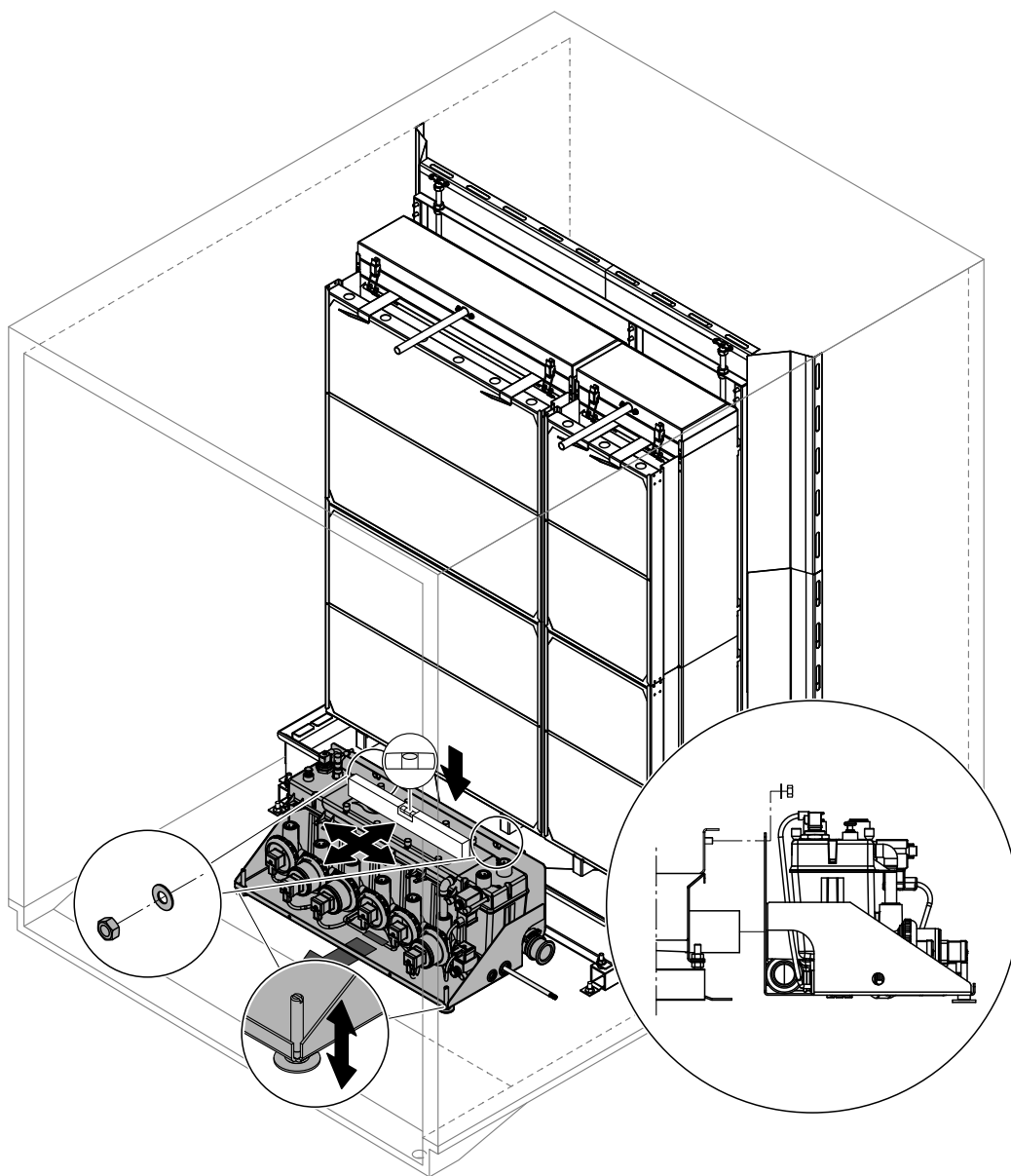


Fig. 22: Mounting the hydraulic module (internal installation)

4.4.2 Mounting the hydraulic module, external installation

Clearances to be observed

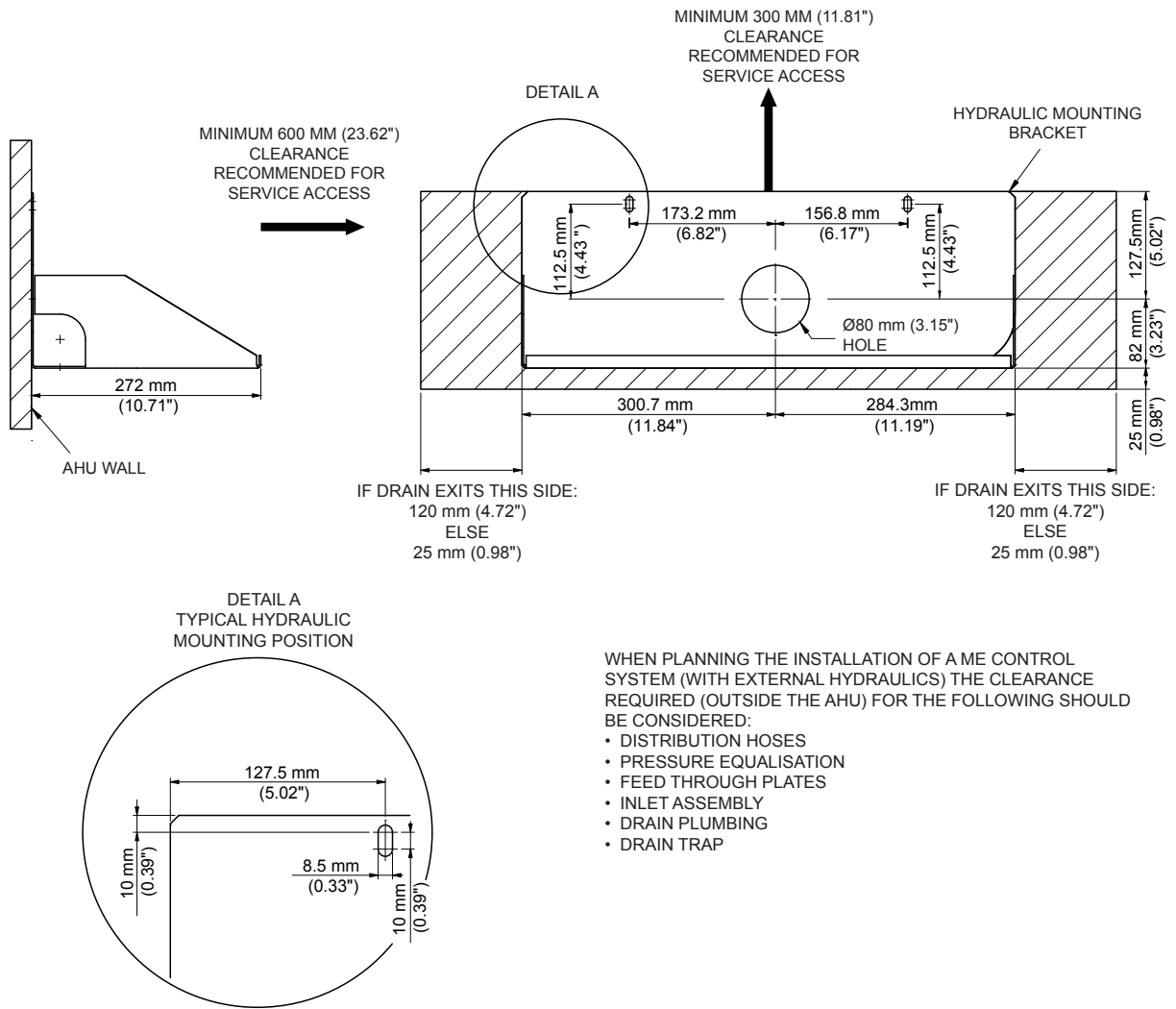


Fig. 23: Clearances to be observed when mounting the hydraulic module externally

Mounting procedure

1. Mark position of the hole for the drain pipe feed through on the AHU/duct wall.
Important: when mounted the drain pipe must have a **downslope of 1 to max. 2 % towards the AHU/duct wall**.
2. Drill hole ($\varnothing 55$ mm (2.2") for centre drain systems or $\varnothing 65$ mm (2.6") for side drain systems) for the drain pipe into AHU/duct wall.
3. Lead drain pipe ($\varnothing 50$ mm or $\varnothing 54$ mm ($\varnothing 2.125$ ") as applicable) through the hole in the AHU/duct wall and connect it to the tank using the elbow union (both supplied as part of an optional tank coupling kit for centre drain systems) or a push-on pipe fitting (supplied with side drain systems).
4. Cut drain pipe to length.
Important: the end of the drain pipe must protrude 46 mm (1.8") minimum to 70 mm (2.75") maximum from the AHU/duct wall. Otherwise correct mounting of hydraulic module is not possible.
5. **Important: De-burr leading edge of drain pipe, to avoid damage to the rubber seal inside the hydraulik module, or injury.**
6. Seal between the pipe and the hole in the AHU/duct wall using silicone-free sealant.
7. Apply **silicone free grease** (e.g. gasket grease) onto the surface of the drain pipe and onto the surface of the rubber sealing inside the connector of the hydraulic module.
8. Then, slide the connector bore of the hydraulic module carefully onto the drain pipe until it comes to a stop.
9. **With the help of a spirit level align hydraulic module exactly horizontal.** Then, fix the hydraulic module to the AHU/duct wall using appropriate fixings.

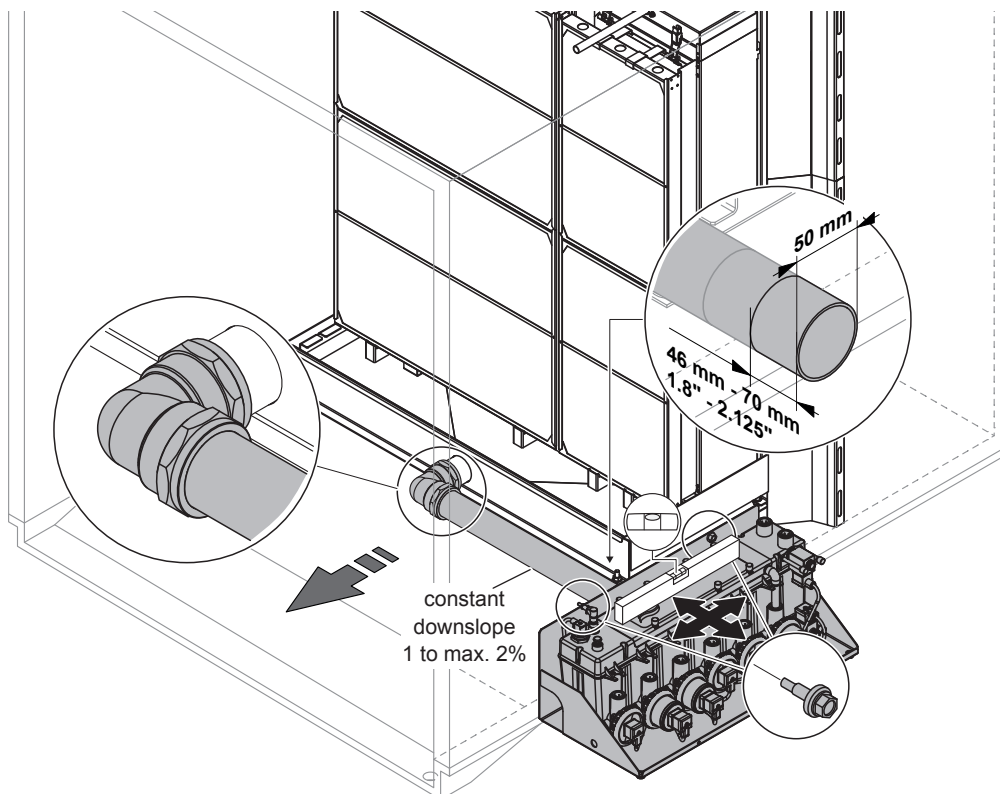


Fig. 24: Mounting the hydraulic module (external installation, centre drain tank)

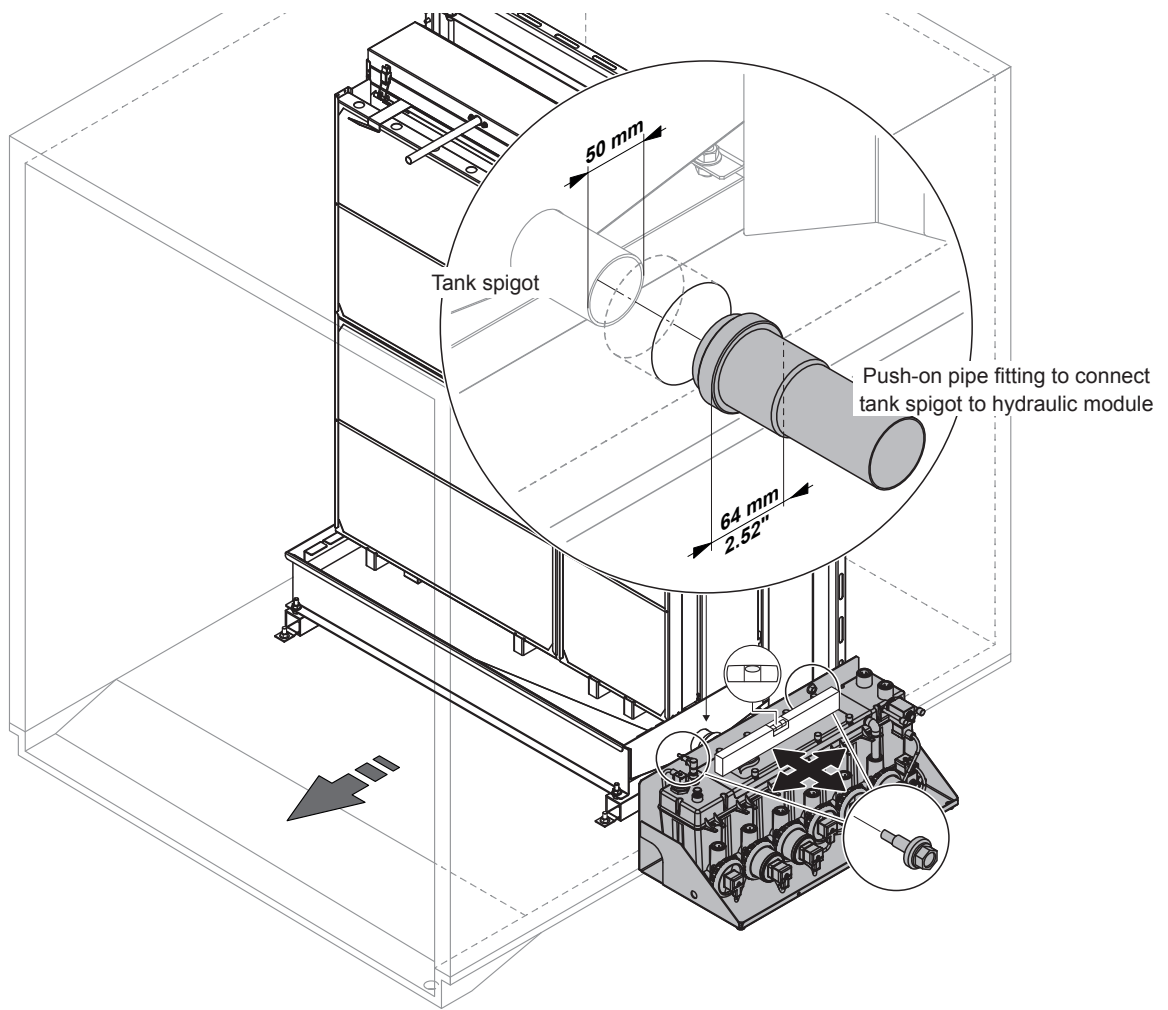
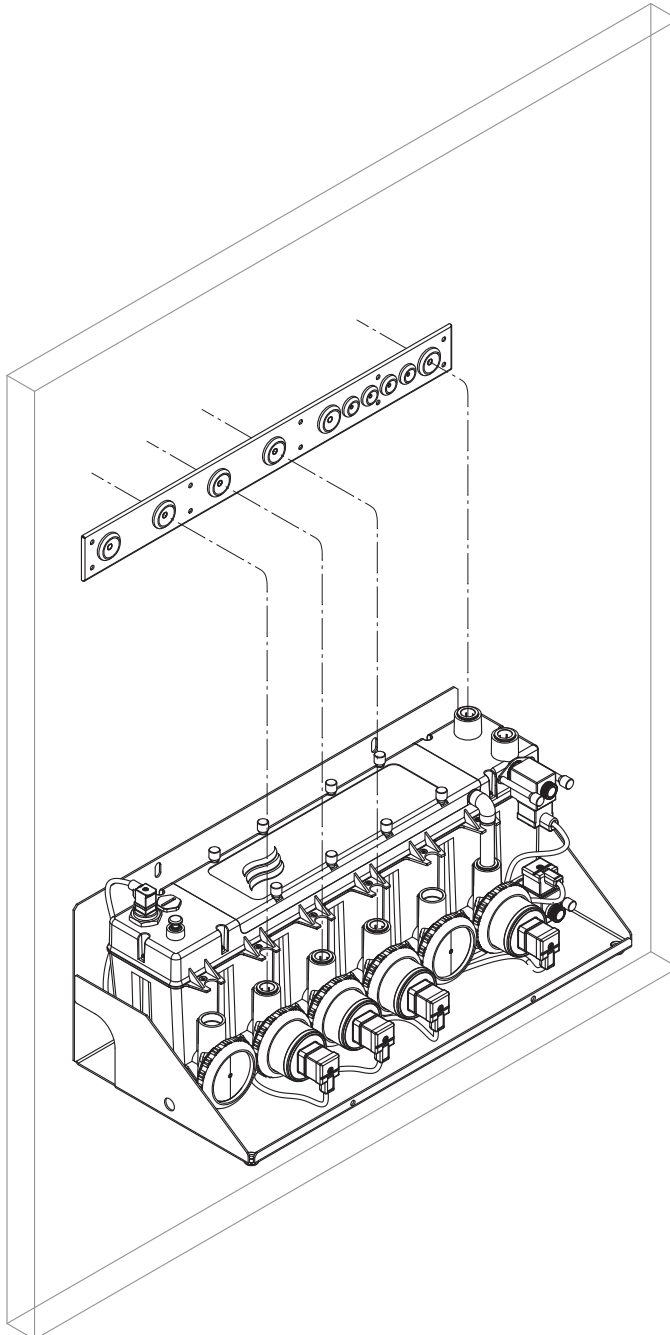


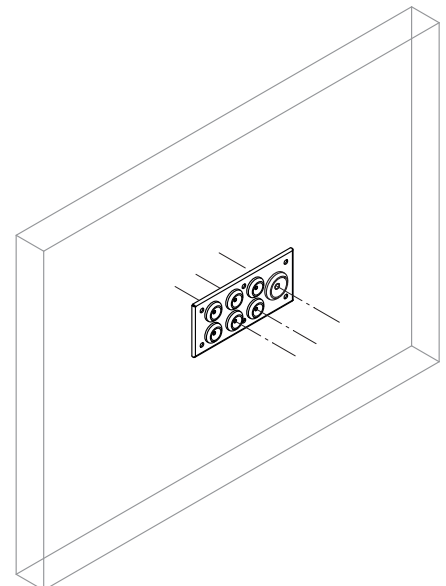
Fig. 25: Mounting the hydraulic module (external installation, side drain tank)

4.5 Mounting the wall feed through plates

1. Push out or pierce the centre of grommets that will have pipes or cable passing through them. Large grommets are for pipe work, and small grommets are for cables.
Note: on feed through plates for use with externally installed hydraulics the large grommets are spaced to match the stage pipe spacing on the hydraulic module, with a wider spaced large grommet at the right end for the pressure equalisation pipe.
2. Using the feed through plate as a guide, mark where the pipes and cables will feed through the AHU wall.

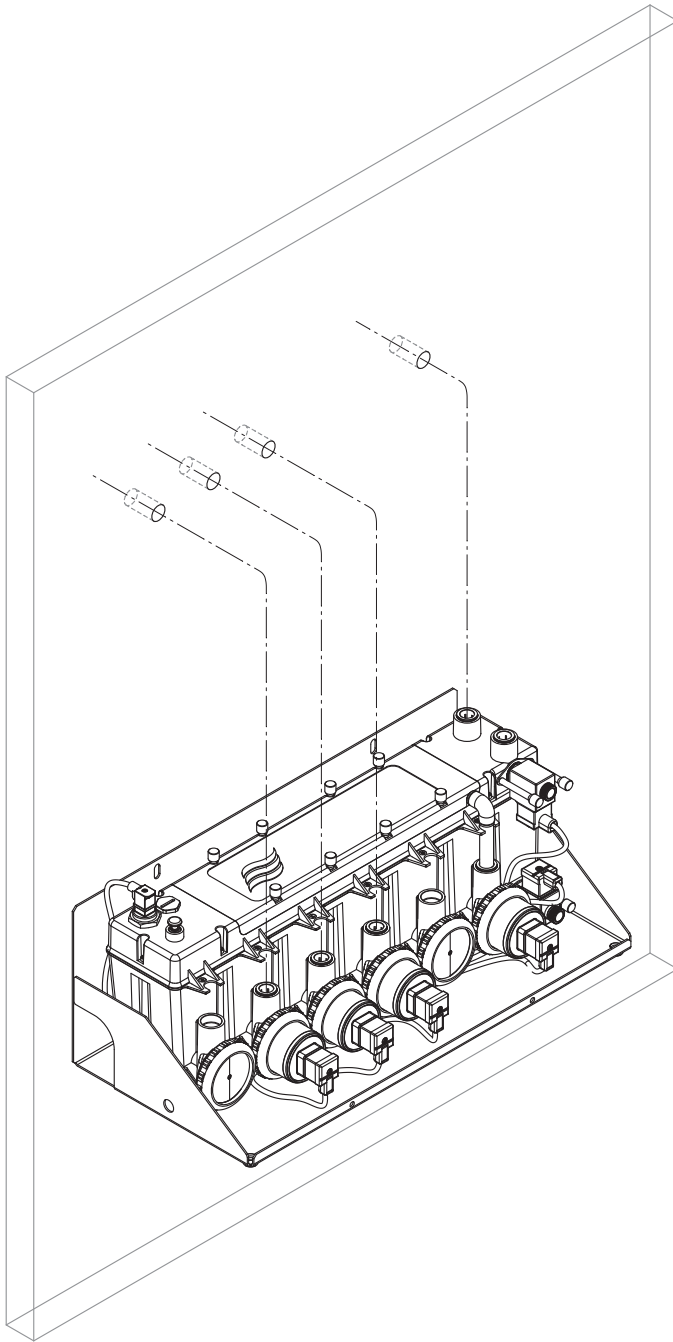


*Fig. 26: Mark feed through holes
(external installation)*

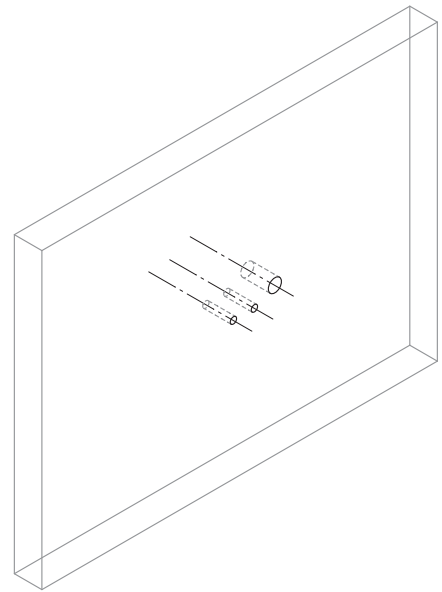


*Fig. 27: Mark feed through holes
(internal installation)*

3. Drill holes through the AHU wall for the pipes and cables. Holes should be as small as possible for the pipe or cable passing through them, and no larger than $\varnothing 12$ mm for the (small) cable grommets, and $\varnothing 20$ mm for the (large) pipe work grommets.



*Fig. 28: Drill feed through holes
(external installation)*



*Fig. 29: Drill feed through holes
(internal installation)*

4. Feed the pipe work (see notes in [chapter 4.6](#)) and cables through the outer feed through plate, then through the AHU wall and finally through the feed through plate on the inner side of the AHU wall.

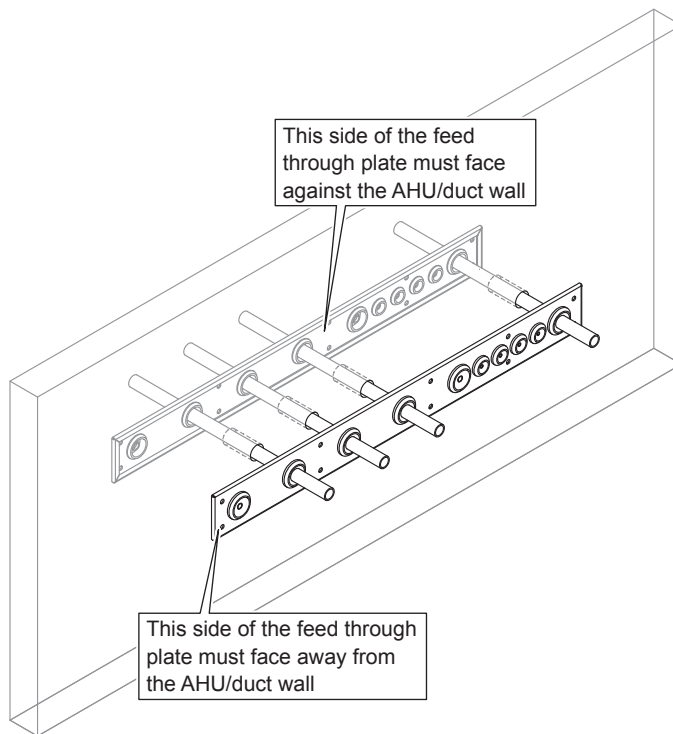


Fig. 30: Mounting the feed through plate (external installation)

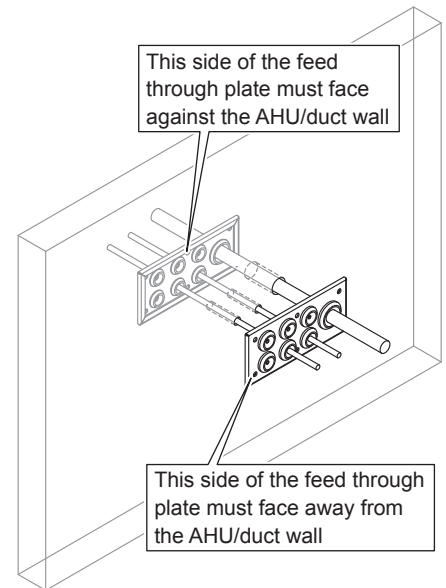


Fig. 31: Mounting the feed through plate (internal installation)

5. Screw the feed through plates to the AHU wall using appropriate fixings.

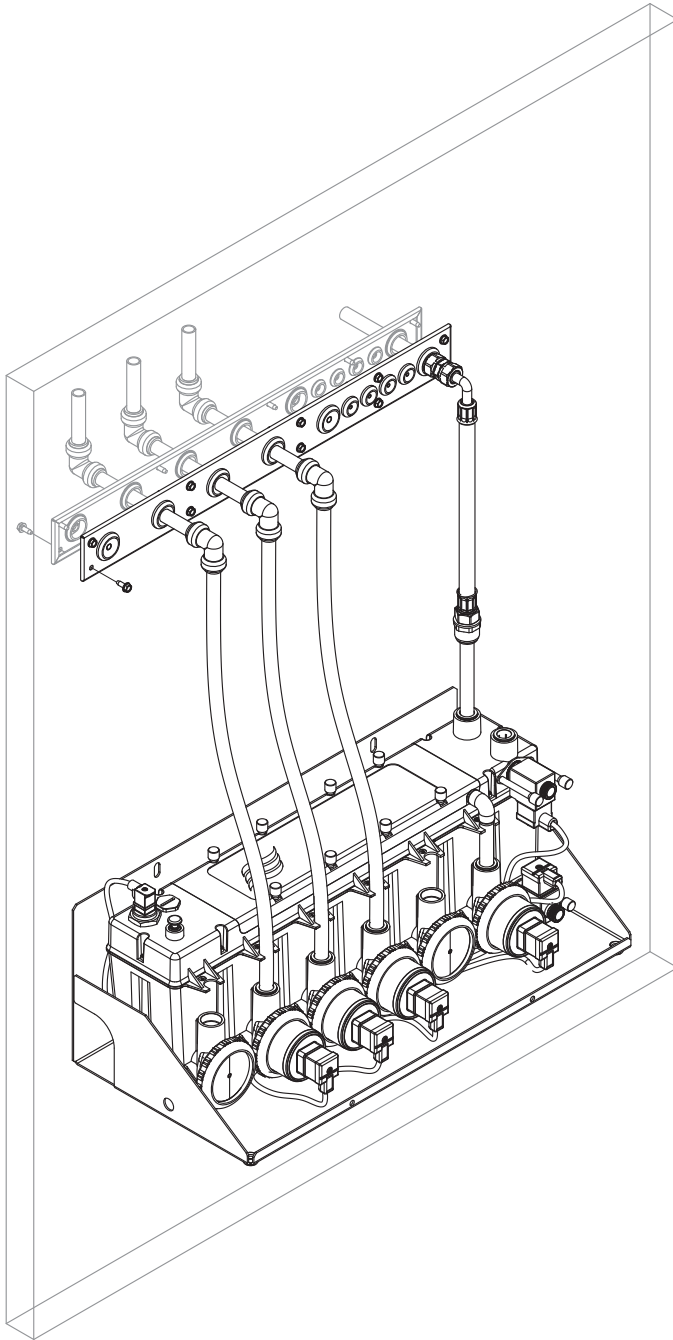


Fig. 32: Fixing the feed through plate to the duct wall (external installation)

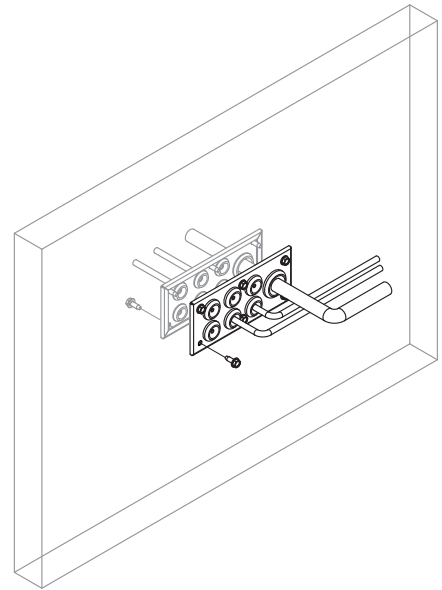


Fig. 33: Fixing the feed through plate to the duct wall (internal installation)

4.6 Water installation

4.6.1 Notes on water installation

The layout of the water piping (supply, drain and distribution piping) depends on the system version. Refer to the corresponding chapter for detailed information and observe the following installation notes.

– Notes on water supply

- The water supply is to be carried out according to the figures found in [chapter 4.6.2](#) and [chapter 4.6.3](#) and the applicable local regulations for water installations. The indicated connection specifications must be observed. The installation material must be supplied by the customer.
- The installation of a **shut-off valve** in the supply line is mandatory and should be made as close as possible to the hydraulic module.
- The water supply pressure should be between 2-5 bar, a pressure regulator should be installed to control the pressure if there is a risk of the pressure exceeding this range.
- The installation material must be rated for the supply pressure and certified for use in drinking water supply systems.
- The fitting that is inserted in the water inlet port of the blue hydraulic module should not be subjected to horizontal force. Ensure that the flexible supply hose is not under tension, and will not be subjected to excessive vibration while the AHU is in operation.
- Regarding supply water quality see appendix.
- The wall feed through for the water supply is provided as part of the installation kit.
Important: after installation the water supply pipe has to be sealed around the feed through using silicone-free sealant, if not using a Condair supplied feed through.
- **Important! To prevent new systems being contaminated with low quality water the entire water supply line must be flushed and tested until the supply water and the bacteria counts, are in line with the water quality specifications, before connecting it to the hydraulic module.** For water quality requirements refer to [chapter 5.1](#).



CAUTION!

After cutting rigid pipes any **sharp edges must be deburred**, as sharp edges may damage the couplings and seals or cause injury.

– **Notes on water drain**

- The water drain line is to be carried out according to the figures found in [chapter 4.6.2](#) and [chapter 4.6.3](#) and the applicable local regulations for water installations. The indicated connection specifications must be observed. The installation material must be supplied by the customer.
- Make sure the drain line is installed with a constant down-slope down to the tundish.
- The drain pipe must not touch the tundish, allow air gap of min. 20 mm.
- Make sure the drain pipe, the drain trap and the tundish are correctly fixed and easily accessible for inspections and cleaning purposes.
- Access hole for the drain pipe through the duct/AHU must be provided by the customer.

Important: after installation seal between drain pipe and AHU/duct wall using silicone-free sealant.

- The minimum inside diameter of the drain pipe must be maintained throughout the entire length!
- The drain pipe must be vented to the interior of the duct in accordance with the figures found in [chapter 4.6.2](#) and [chapter 4.6.3](#). The end of the drain pipe vent that is within the duct must be higher than the maximum tank water level.

– **Note on pressure equalisation for external mounted systems**

The hydraulic module must be equipped with a pressure equalisation pipe connected to the interior of the duct to ensure the water level in the hydraulic module corresponds with the water level in the tank inside the duct (see figure in [chapter 4.6.3](#)).

– **Notes on distribution piping**

- The distribution piping is to be carried out according to the figures found in [chapter 4.6.2](#) and [chapter 4.6.3](#) and the applicable local regulations for water installations. The indicated connection specifications and connection layout must be observed.
- The distribution piping is made of $\varnothing 15$ mm flexible plastic hoses (supplied with internally installed systems) or stainless steel pipe/rigid plastic pipes (which can be supplied as part of an optional external installation kit).
- Make sure the distribution hoses have a constant downslope (no sagging) to the hydraulic module and are not kinked over the entire length.

General notes on installation of the hoses (Internal Installation)

- Use the supplied $\varnothing 15$ mm flexible plastic hoses only. For hygienic reasons do not use other hoses (except products supplied by your Condair distributor).
- When cutting hoses use an **appropriate cutting tool** providing **straight, kink-free** cuts.



CAUTION!

After cutting the hoses any **sharp edges must be deburred** otherwise the couplings may be damaged.

- The hoses must be free of kinks and other damage (longitudinal scratches or misshaped ends, in particular).
- When cutting hoses **ensure at least 25 mm** is added to the required length, to ensure the hoses can be fastened correctly (down to the stop) in the push-fit couplings.
- Make sure the hoses are not kinked and pay attention to the **minimum bend radius of 100 mm**.
- Do not lead hoses past hot system components (**max. ambient temperature is 60 °C**).
- After installation verify correct fastening of all hoses. Correctly mounted hoses can not be removed without pressing the locking ring.



CAUTION!

In order to avoid damage caused by leaking water during operation, all hoses must be correctly secured against accidentally pulling out.

4.6.2 Water installation (internal installation)

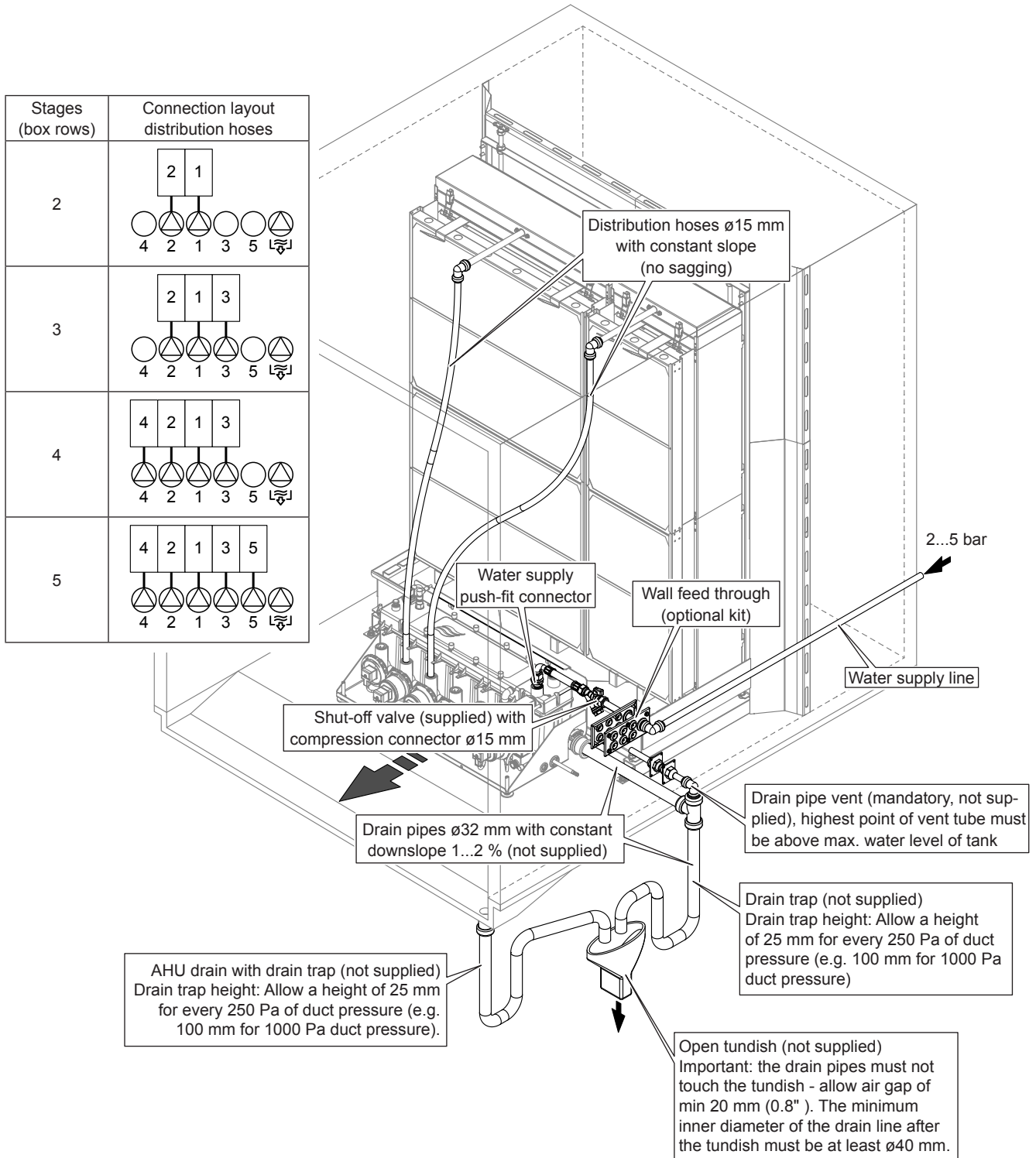


Fig. 34: Water installation (internal installation)

4.6.3 Wasser installation (external installation)

4.6.3.1 Water installation (external installation, centre drain tank)

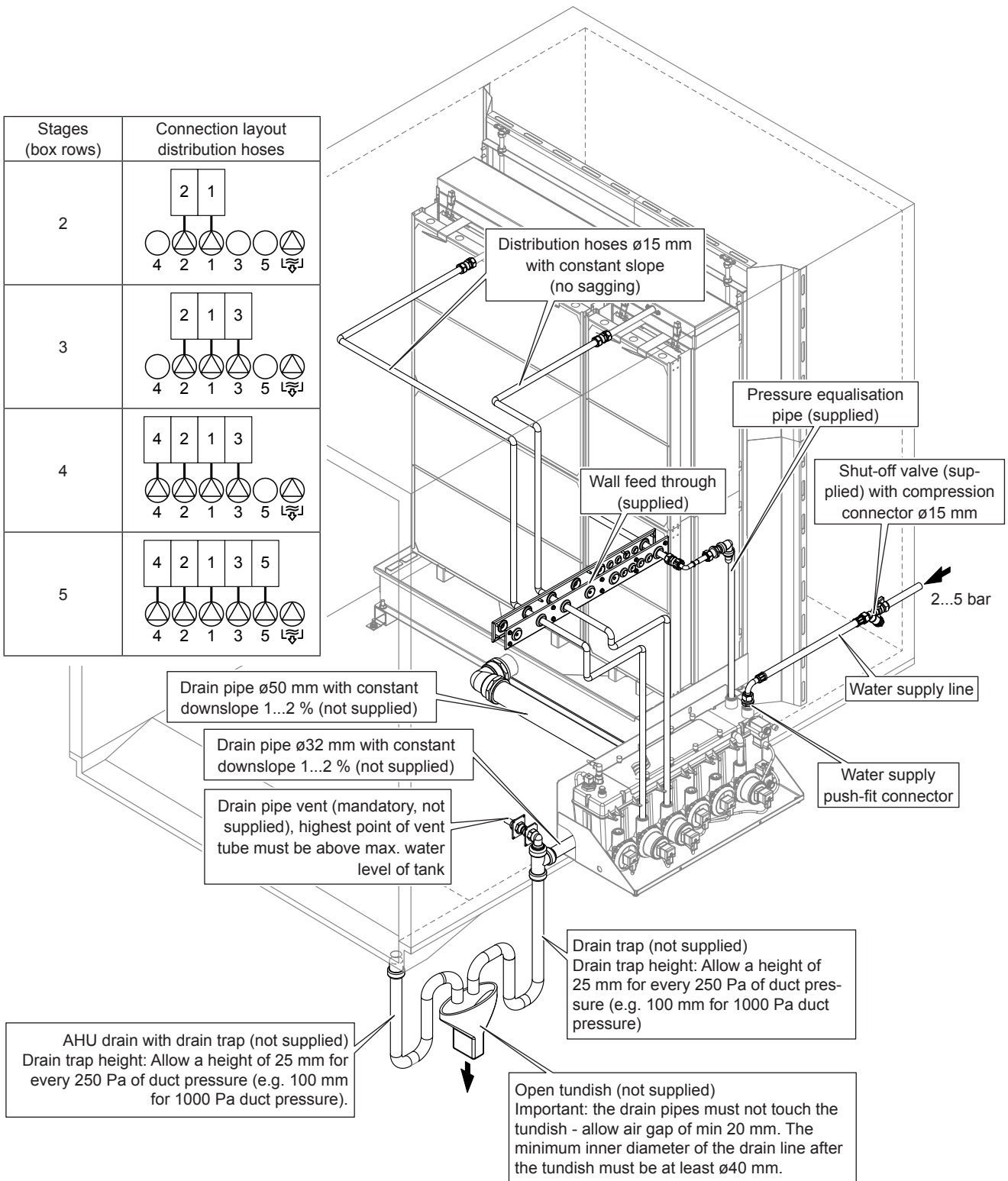


Fig. 35: Water installation (external installation, centre drain tank)

4.6.3.2 Water installation (external installation, side drain tank)

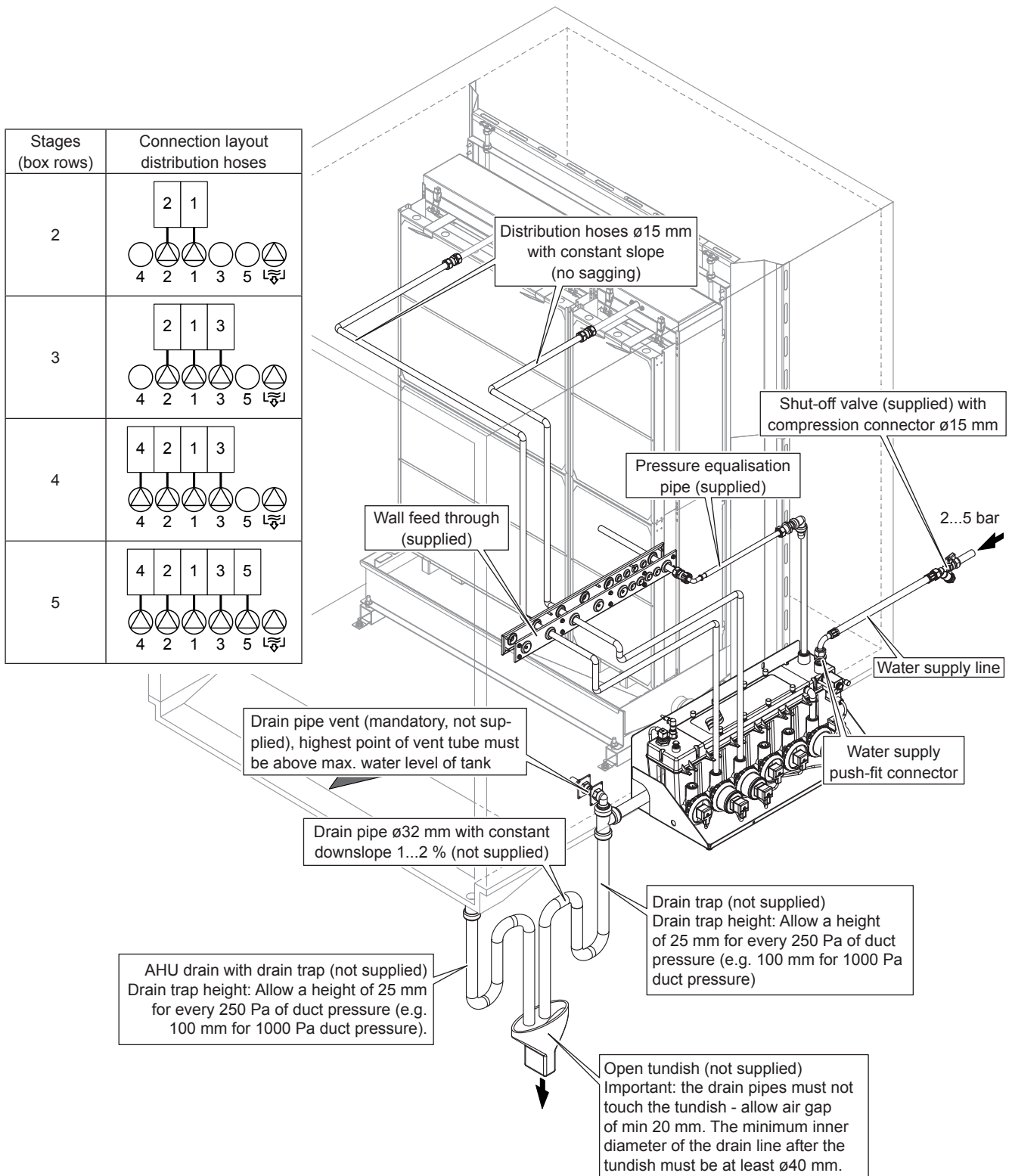


Fig. 36: Water installation (external installation, side drain tank)

4.7 Mounting the control unit

4.7.1 Notes on positioning the control unit

Please observe the following notes when positioning the Condair ME control unit:

- The control unit can be mounted directly outside to the AHU/air duct or to a wall or stand (not supplied).
- The control unit should ideally be positioned as close to the evaporative module as possible for ease of servicing and maintenance.

Note: the hydraulic module of the Condair ME Control is equipped with a 10 m multi-wire electrical inter-connecting cable for connection to the control unit. Make sure the control unit is mounted within the range of the inter-connecting cable.

- The control unit is protected according to **IP21**. Make sure the control unit is installed in a drip-proof location and the admissible ambient conditions are complied with (see technical data in the operation manual to the Condair ME Control).
- The power supply to the control unit must be equipped with an electrical isolator (not supplied) fitted within 1 m (39") for purposes of maintenance and emergencies. When positioning the control unit make sure the electrical isolator can be mounted within that range.

4.7.2 Recommended access requirements of the control unit

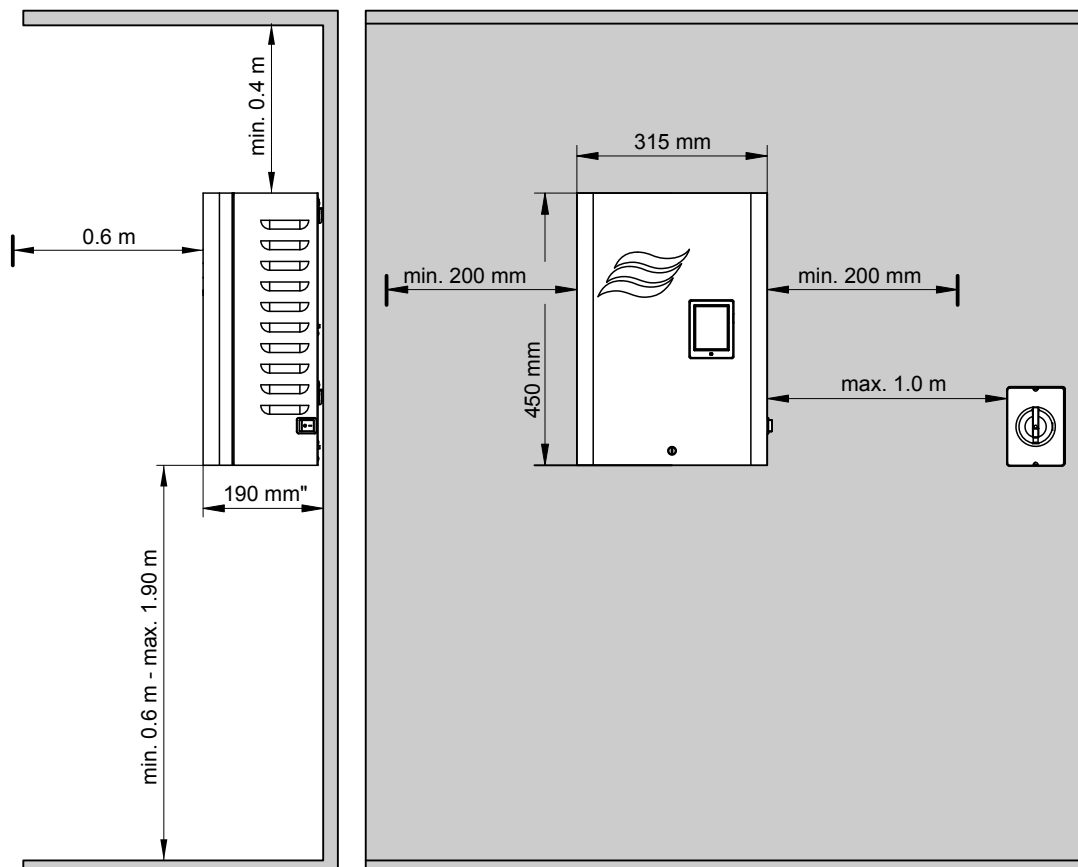


Fig. 37: Recommended access requirements of the control unit

4.7.3 Mounting the control unit

Important: if multiple systems have been supplied to a site, ensure that the serial number on the control panel corresponds to the serial number marked on the hydraulic module and the evaporative module.

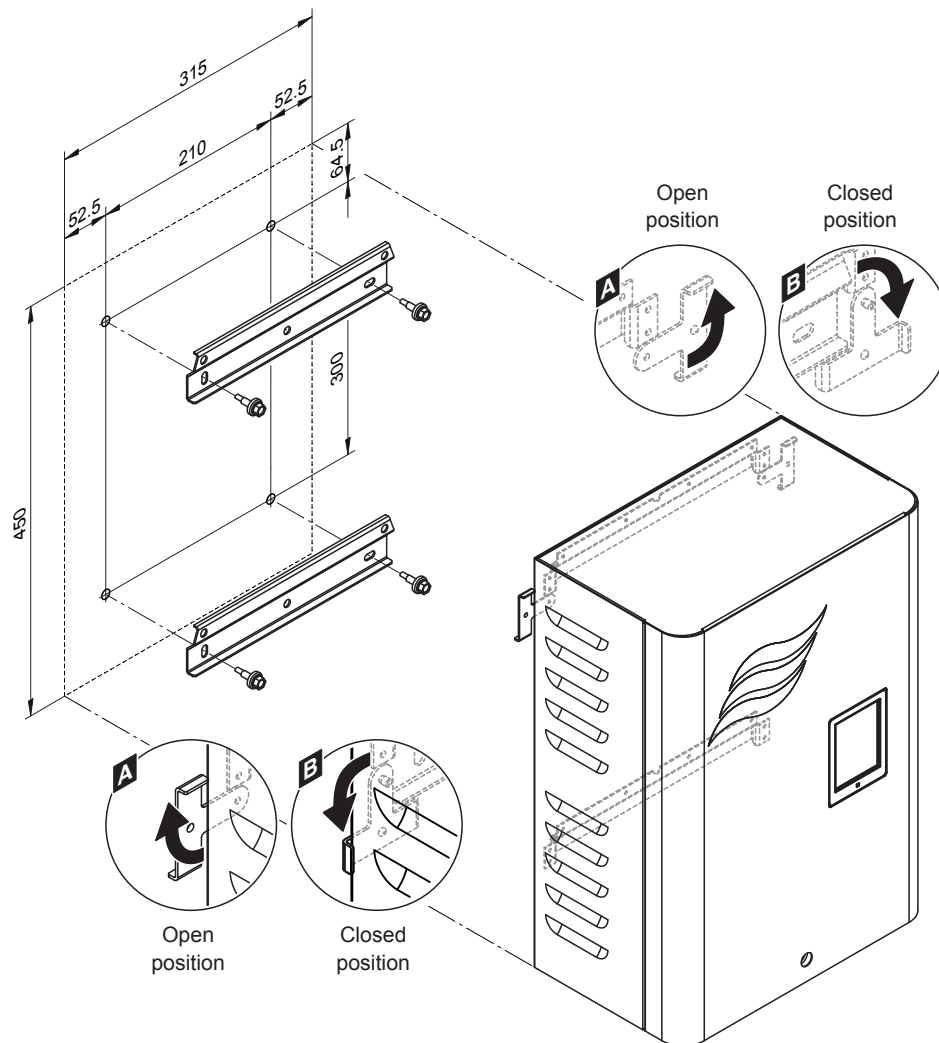



Fig. 38: Mounting the control unit of Condair ME Control (dimensions in mm)

Mounting procedure:

1. Mark the attachment points for the upper and lower wall support at the desired position with the help of a level.
2. Fix the wall supports to the wall using appropriate fixings. Before tightening the fixings adjust the wall supports horizontally using a level.
3. Move the locking hooks on the back of the control panel to open position (see [detail "A" in Fig. 38](#)).
4. Hang up the control unit onto the wall supports.
5. Move the locking hooks on the back of the control panel to closed position (see [detail "B" in Fig. 38](#)) in order to fix the control unit to the upper wall support.

4.8 Electrical installation

4.8.1 Notes on electrical installation

 **DANGER!**
Risk of electric shock!

The control unit contains live mains voltage. Live parts may be exposed when the control unit is open. Touching live parts may cause severe injury or danger to life.

Prevention: The control unit must be isolated from the mains before commencing any installation work.

 **WARNING!**

The **electronic components** inside the control unit are **very sensitive to electrostatic discharge**. Before carrying out installations work inside the control unit, appropriate **measures must be taken to protect the electronic components against damage caused by electrostatic discharge (ESD protection)**.

- All work concerning the electrical installation must be performed only by **skilled and qualified technical personnel (e.g. electrician or technicians with appropriate training)** authorised by the owner. It is the owner's responsibility to verify proper qualification of the personnel.
- The electrical installation must be carried out according to the appropriate wiring diagram (see [chapter 4.8.2](#)), the notes on electric installation as well as the applicable local regulations. All information given in the wiring diagram must be followed and observed.
- All cables must be led into the control unit via the cable feed throughs on the bottom side of the control unit. The mains cable must be led into the control unit via the cable opening equipped with the cable gland on the right side.

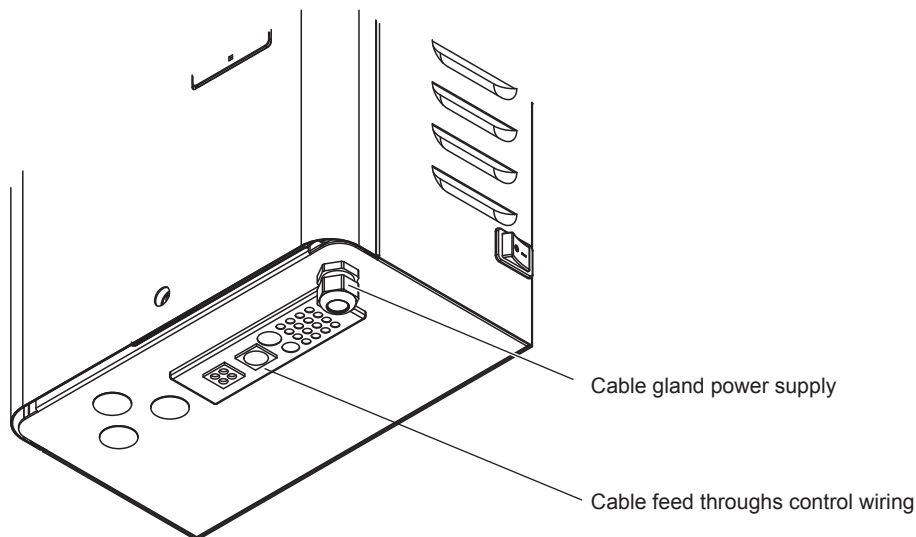
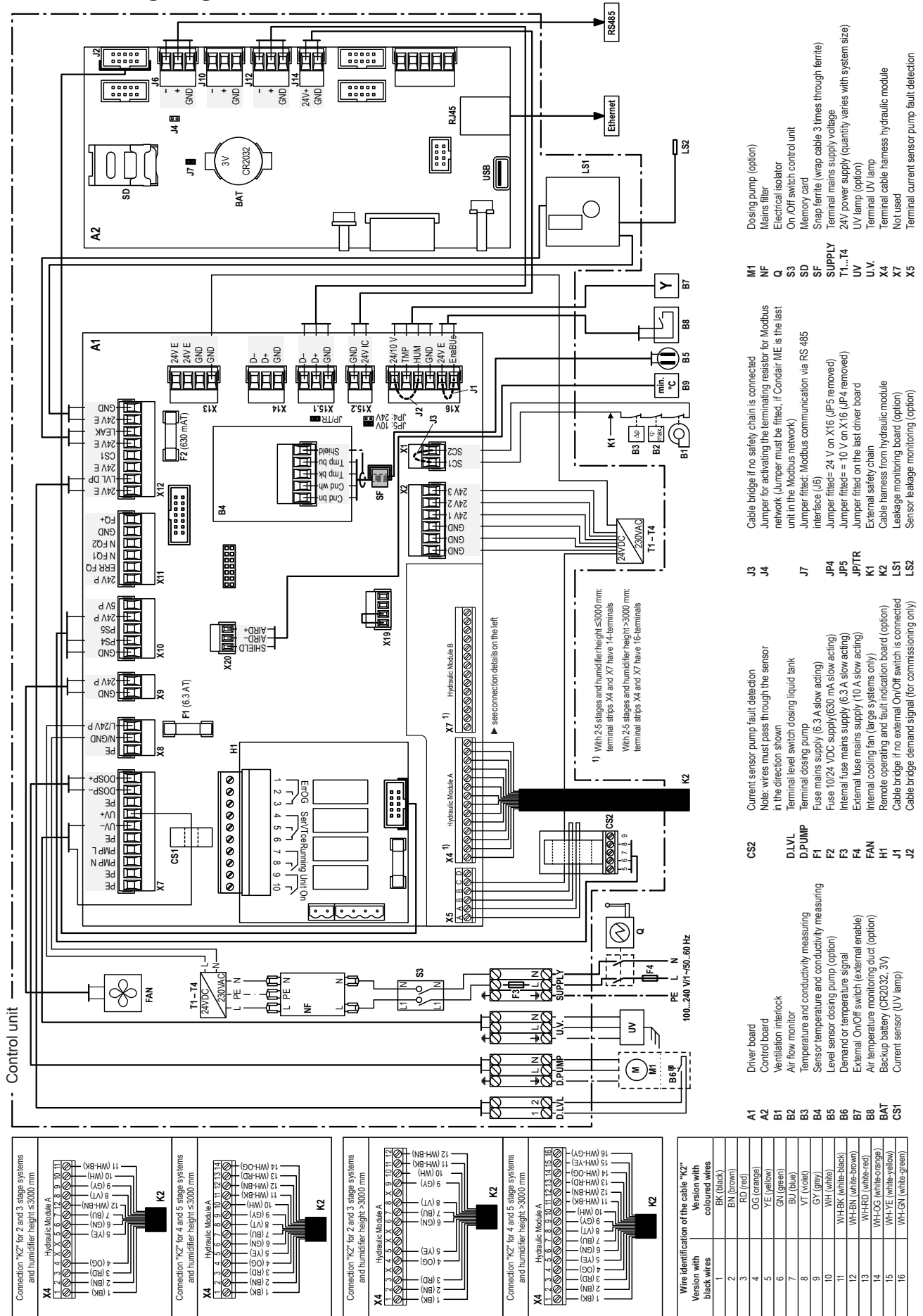


Fig. 39: Cable feed throughs control unit

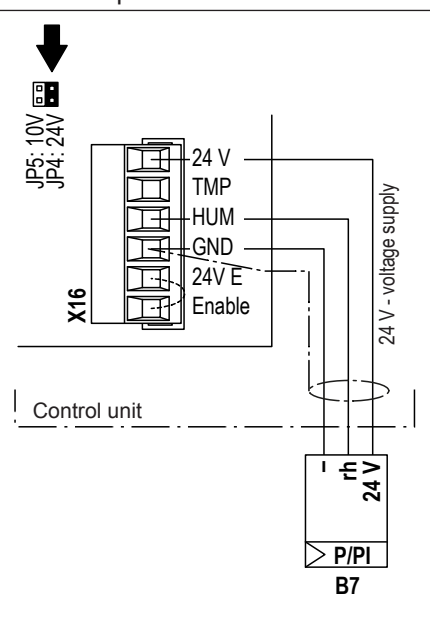
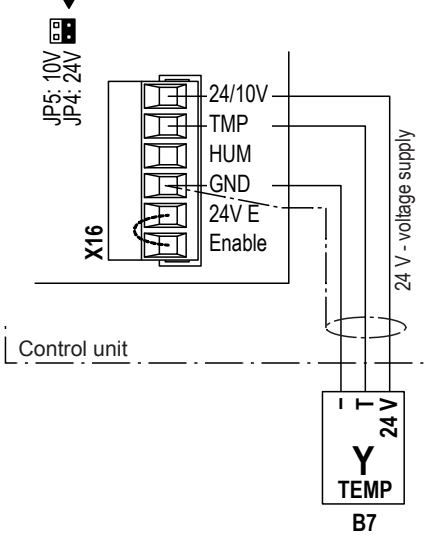
- All cables from the hydraulic module mounted inside the AHU/air duct must be led via appropriate cable gland(s) out of the AHU/air duct.
- Ensure cables are secured in such a way that the insulation is not damaged by sharp edges and so that they do not create a trip hazard.
- Observe and maintain maximum cable length and required cross section per wire according to local regulations.
- The mains supply voltage must match the respective voltage stated on the rating plate.

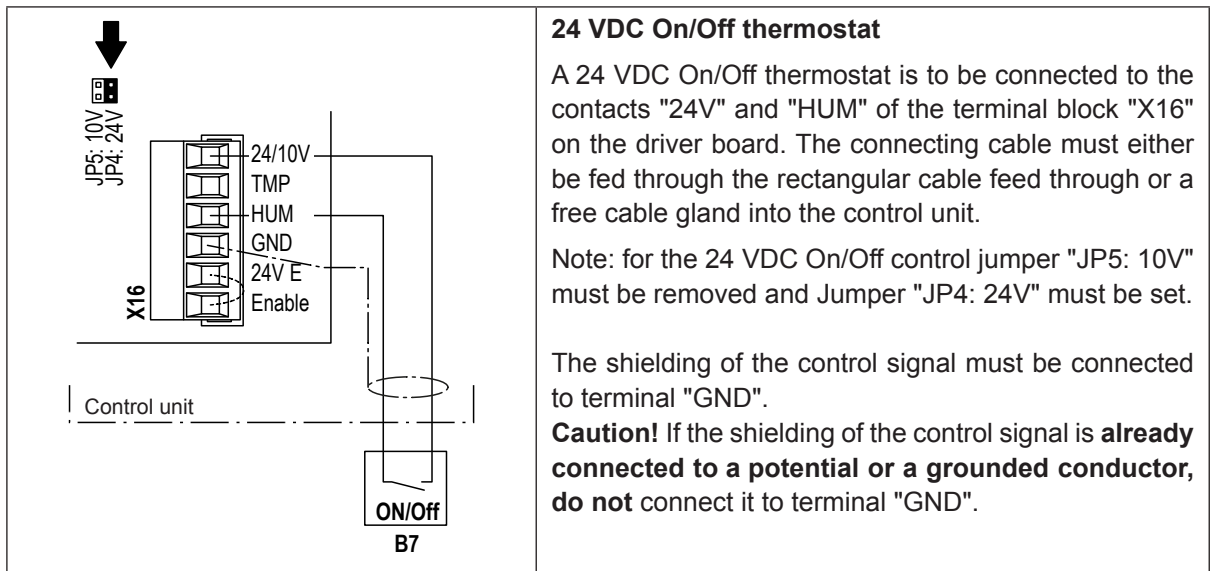
4.8.2 Wiring diagram Condair ME Control



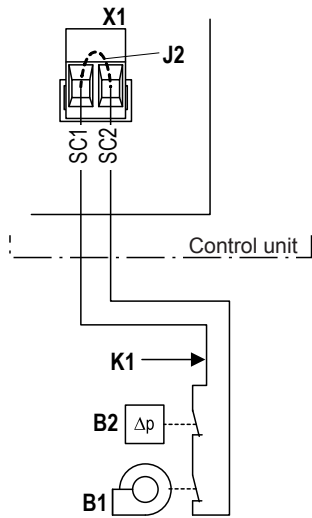
4.8.3 Installation work

Note: for the connection of the available options please refer to the addendum manual of the corresponding option.

Control signal (Y)	
<p>Note: the control settings must be done via the control software of the Condair ME Control. Please refer to the operation manual of the Condair ME Control.</p> 	<p>External continuous temperature controller</p> <p>An external continuous temperature controller is to be connected to the contacts "HUM" (+) and "GND" (-) of the terminal block "X16" on the driver board in accordance with the wiring diagram. The admissible signal values can be found in the technical data table in the operation manual. The connecting cable must either be fed through the rectangular cable feed through or a free cable gland into the control unit.</p> <p>Note: If 24V supply is used for the external controller Jumper "JP4: 24V" must be set and Jumper "JP5: 10V" must be removed.</p> <p>The shielding of the control signal must be connected to terminal "GND".</p> <p>Caution! If the shielding of the control signal is already connected to a potential or a grounded conductor, do not connect it to terminal "GND".</p>
	<p>Temperature sensor</p> <p>A temperature sensor is to be connected to the contacts "TMP" (+) and "GND" (-) of the terminal block "X16" on the driver board. The admissible signal values can be found in the technical data table in the operation manual. The connecting cable must either be fed through the rectangular cable feed through or a free cable gland into the control unit.</p> <p>Note: If 24V supply is used for the temperature sensor Jumper "JP4: 24V" must be set and Jumper "JP5: 10V" must be removed.</p> <p>The shielding of the control signal must be connected to terminal "GND".</p> <p>Caution! If the shielding of the control signal is already connected to a potential or a grounded conductor, do not connect it to terminal "GND".</p>



External safety circuit



To guarantee the safety of the cooling system, monitoring the operation by means of a safety circuit "K1" is an absolute requirement.

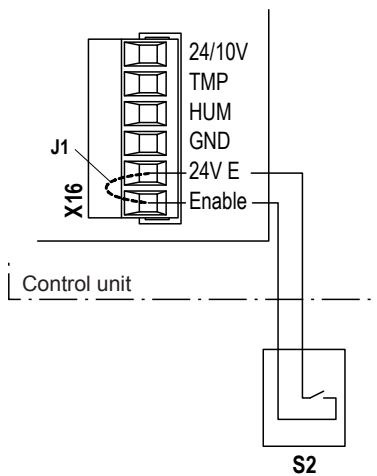
To accomplish this, the **potential-free contacts** of external monitoring devices (e.g. ventilation interlock "B1", airflow monitor "B2", etc.) are **connected in series to the contacts "SC1" and "SC2" of the terminal block "X1"** on the driver board in accordance with the wiring diagram. The connecting cable must either be fed through the rectangular cable feed through or a free cable gland into the control unit.

If, for whatever reason, no external monitoring devices are connected, a cable bridge "J2" must be installed on the contacts "SC1" and "SC2" of the terminal block "X1".

Do not apply any **extraneous voltage** to contacts **"SC1" and "SC2"** via the contacts of the external monitoring devices.

The cross-section of the connecting cable must comply with the applicable local regulations (minimum 1 mm²).

External enable



The **potential-free contact** of an external enable switch is **connected to the contacts "24 V E" and "Enable" of the terminal block "X16"** on the driver board in accordance with the wiring diagram. The connecting cable must either be fed through the rectangular cable feed through or a free cable gland into the control unit.

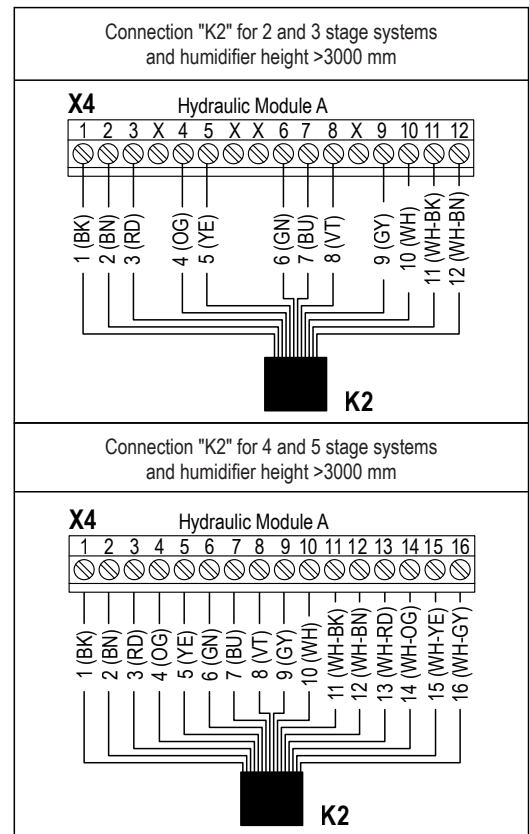
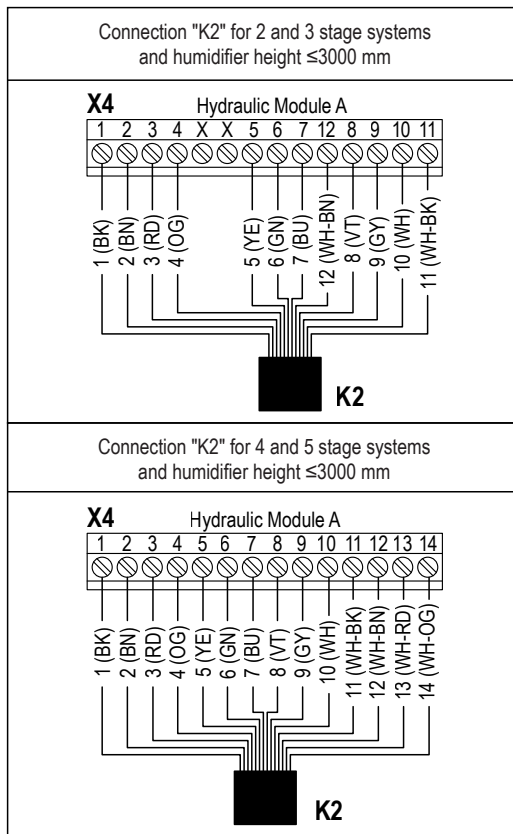
If no external enable switch is connected, a cable bridge "J1" must be installed on the contacts "24V E" and "Enable" of the terminal block "X16".

CAUTION! Do not apply any extraneous voltage to terminals via the enable switch.

Connecting the multi-wire inter-connecting cable from the hydraulic module

Note: The multi-wire inter-connecting cable is supplied with numbered black wires or colored wires. When connecting the multi-wire inter-connecting, observe the table below with the identification of the wires.

Wire identification of the cable "K2"	
Version with numbered black wires	Version with coloured wires
1	BK (black)
2	BN (brown)
3	RD (red)
4	OG (orange)
5	YE (yellow)
6	GN (green)
7	BU (blue)
8	VT (violet)
9	GY (grey)
10	WH (white)
11	WH-BK (white-black)
12	WH-BN (white-brown)
13	WH-RD (white-red)
14	WH-OG (white-orange)
15	WH-YE (white-yellow)
16	WH-GN (white-green)

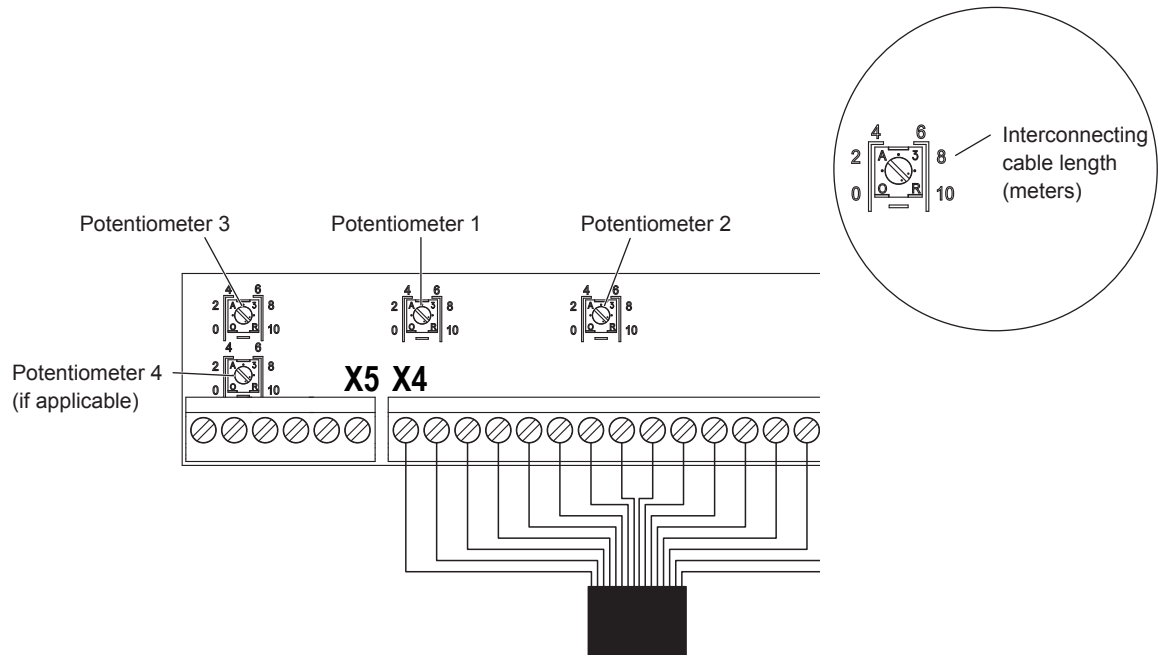


The multi-wire inter-connecting cable "K2" from the hydraulic module is to be connected to the corresponding terminals of terminal block "X4" according to the appropriate wiring diagram shown above. The multi-wire inter-connecting cable must be fed through the rectangular cable feed through into the control unit.

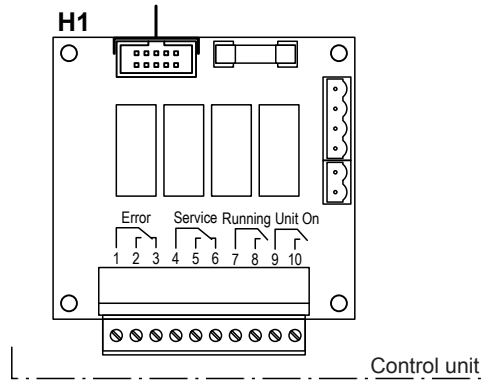
The 10 m inter-connecting cable has to be cut to length on site. If terminal block "X4" has 14 terminals, and "K2" has 16 coloured wires, cut back the 2 unused wires.

Once the multi-wire inter-connecting cable from the hydraulic module has been cut to the required length, set all the potentiometers on the distribution board to the number that corresponds to the length of the inter-connecting cable ("K2") in metres.

Note: Potentiometer 4 is only present on systems over 3 m tall.



Connecting the remote operating and fault indication (option)



The optional remote operating and fault indication board contains four potential-free relay contacts for the connection of the following operating and fault indications:

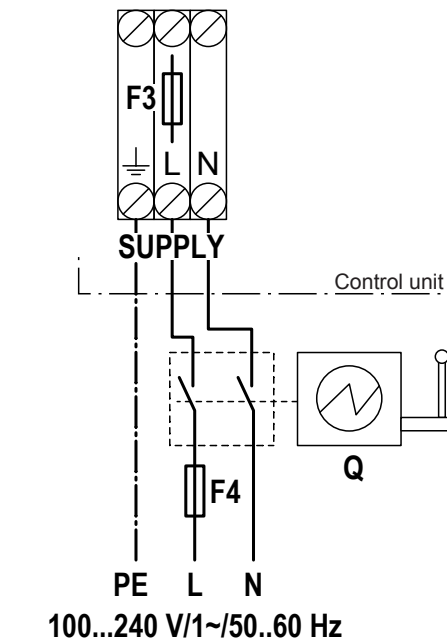
- "Error":
This relay is activated if an error is present.
- "Service":
This relay is activated when the set service interval has expired.
- "Running":
This relay closes as soon as the Condair ME is cooling.
- "Unit on":
This relay closes as soon as the voltage supply to the control unit of the Condair ME is switched on.

The connecting cable must either be fed through the rectangular cable feed through or a free cable gland into the control unit.

The **maximum contact loading is 250V/8A.**

Appropriate suppressor modules are to be used for the switching of relays and miniature contactors.

Mains voltage supply



CAUTION! Before connecting the mains voltage supply, make sure the voltage indicated on the rating plate meets the local line voltage. Otherwise, do not connect the control unit.

Connect **mains voltage supply** 100...240V/1~/50...60Hz in accordance with the wiring diagram, to the **terminal block "SUPPLY"** in the control unit. The mains supply cable must be led into the control unit via the cable gland on right side on the bottom of the control unit.

The installation of the **fuse F4** (10A, slow acting), the **electrical isolator "Q"** (all pole disconnecting device with a minimum contact clearance of 3 mm/0.12") and a fault current protection switch with 30 mA trigger current (by client) in the mains supply line **are mandatory**.

The electrical isolator must be mounted in direct proximity of the control unit (max. distance 1 m/39.37") and must be easily accessible in a height between 0.6 m/23.62" and 1.9 m/74.8" (recommended: 1.7 m/66.93").

The cross-section of the mains cable must comply with the applicable local regulations (min. 1.5 mm²/0.0023 sq.in.).

5 Appendix

5.1 Inlet water quality requirements

For the water supply of the Condair ME Control, use exclusively untreated tap water, fully demineralised water, fully softened water or partly softened water with a max of **100 cfu/ml**.

For areas with tap water with high water hardness the Condair ME Control should be supplied with water from a reverse osmosis system (RO).

Since tap water quality differs locally very much, please contact your Condair representative before using tap water.

Which type of evaporative cassettes for which type of water!

Type evaporative cassette	Suitable for
Polyester	Tap water, fully softened or partly softened water and fully demineralised water
Fibre	Tap water and fully softened or partly softened water

CONSULTING, SALES AND SERVICE:



CH94/0002.00

Condair Group AG
Gwattstrasse 17, 8808 Pfäffikon SZ, Switzerland
Phone +41 55 416 61 11, Fax +41 55 588 00 07
info@condair.com, www.condairgroup.com

The Condair logo features a stylized graphic of three wavy lines to the left of the word 'condair' in a bold, lowercase, sans-serif font.